

MONTAGE[®]



RESIDENTIAL ORNAMENTAL STEEL FENCE

Montage ornamental steel fence is *unparalleled in strength* and quality, *adapts to virtually any terrain, withstands vast shifts in climate* yet remains untouched by time in stately elegance. This fence offers an *array of customizable options* to fit your unique sense of style and application.



PRIMARY APPLICATIONS

- ***Single Family Residence***
- ***Apartments (Multi-Family)***



FENCE PRODUCTS

AMERISTARPERIMETER.COM | 888-333-3422
Experience a safer and more open world

AMERISTAR[®]

ASSA ABLOY

MONTAGE®

RESIDENTIAL ORNAMENTAL STEEL FENCE

.625"sq x 18ga PICKETS | .9375" x 1.25" x 14ga RAILS | 2"sq x 16ga POSTS

Each picket is precisely welded at each rail intersection providing all-terrain flexibility and aesthetics.

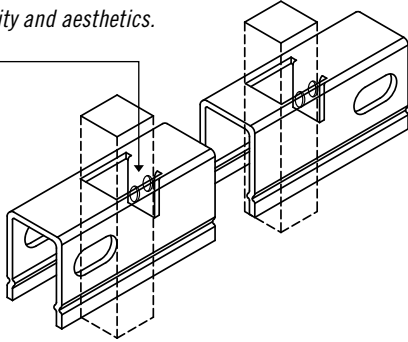

STYLE OPTIONS



Also available in Pool, Pet & Play (3" air spacing) – styles vary



PROFUSION WELDED STEEL

All Montage fence panels are fabricated using Ameristar's ProFusion welding process. This technique combines laser and fusion technology to create a virtually invisible structural connection at every picket-to-rail intersection. Unlike typical aluminum fence systems that are held together with unsightly screws, the ProFusion weld used with Montage promotes a "good neighbor" profile with sleek lines and no exposed picket-to-rail fasteners. When compared to aluminum fencing, Montage's welded steel construction is unmatched in strength and durability.



E-COAT™ PROTECTIVE FINISH

Montage galvanized steel framework is subjected to a multi-stage pre-treatment/wash (*with zinc phosphate*), followed by a duplex cathodic electrocoat system consisting of an epoxy primer, which significantly increases corrosion protection, and an acrylic topcoat, which provides the protection necessary to withstand adverse weathering effects. This process results in years of maintenance-free ownership.



LIFETIME LIMITED WARRANTY

The Montage families of fencing products are manufactured from superior quality materials by skilled craftsmen with the highest standards of workmanship in the industry. Ameristar is confident in offering Montage with a Lifetime Warranty, backed by an American company with over 30 years of demonstrated excellence in manufacturing ornamental fence products.



DOMESTIC MANUFACTURING

Ameristar is committed to providing products that are manufactured in the USA. We have made significant investments in technology, process improvement, and employee training in an effort to secure American jobs and combat inferior import products.



FENCE PRODUCTS

TO PLACE YOUR ORDER CALL 888-333-3422 | VISIT AMERISTARPERIMETER.COM

MONTAGE® | 2 & 3-RAIL OPTIONS | 3" & 4" AIR-SPACE OPTIONS

STANDARD BOTTOM & FLUSH BOTTOM OPTIONS AVAILABLE

PATENT NUMBERS: 7071439, 7282659, 7621510, 7896318,
7980534, 8523150, 9840854, 10538939

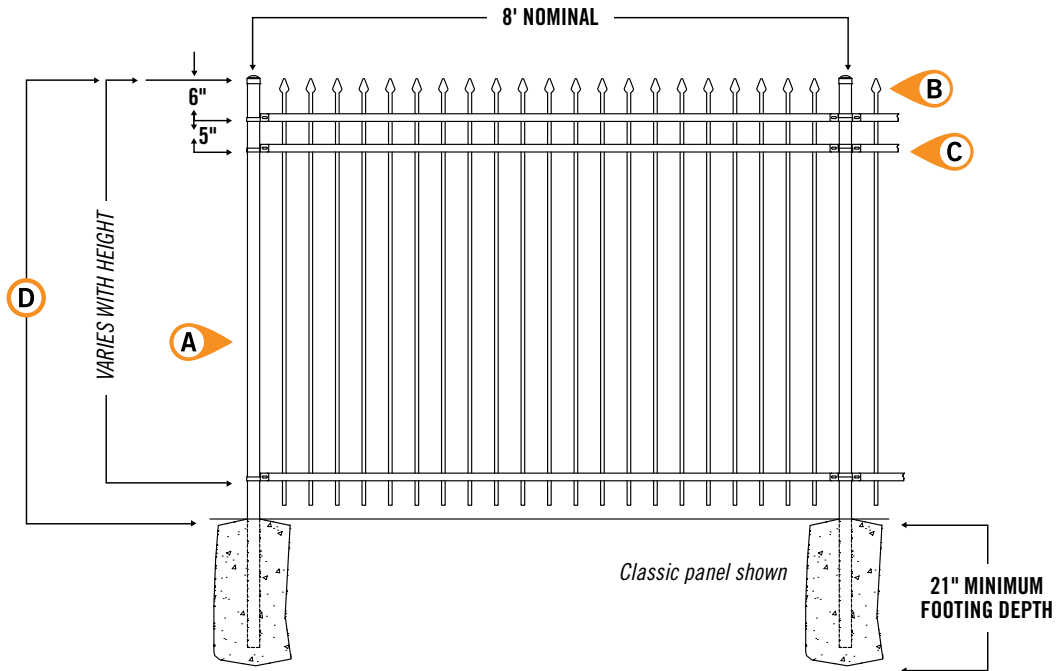

- Ⓐ 2"sq x 16ga POSTS
- Ⓑ 0.590"sq x 18ga PICKETS
- Ⓒ 0.9375"w x 1.25"h x 14ga RAILS
- Ⓓ 3', 3.5', 4', 4.5', 5' & 6' PANEL HEIGHTS

Refer to construction specification & tables within this section for recommended post space by bracket type

Effective: 05/01/2024

MONTAGE® | 2-RAIL PANELS | 4" AIR GAP

STANDARD BOTTOM | 8' PANEL LENGTH (94" actual width) | 21 PICKETS PER PANEL | 40 PANELS PER PALLET

PANEL	ITEM NUMBER	WEIGHT	STOCKING
3'	R☒⊗234	30 lbs	⊙
3.5'	R☒⊗240	33 lbs	⊙
4'	R☒⊗246	36 lbs	CB MB GB
5'	R☒⊗258	43 lbs	CB MB

☒ = FENCE STYLES AVAILABLE | **C** = Classic **M** = Majestic **G** = Genesis
W = Warrior **L** = Crescent*

⊗ = COLOR OPTIONS AVAILABLE | **B** = Black

⊙ = NON-STOCKED PRODUCT

For details, see Ameristar's Sales Policy in the catalog guide.

Notes: Genesis panels are packaged with BLACK picket plugs.

* Not Rackable panels.

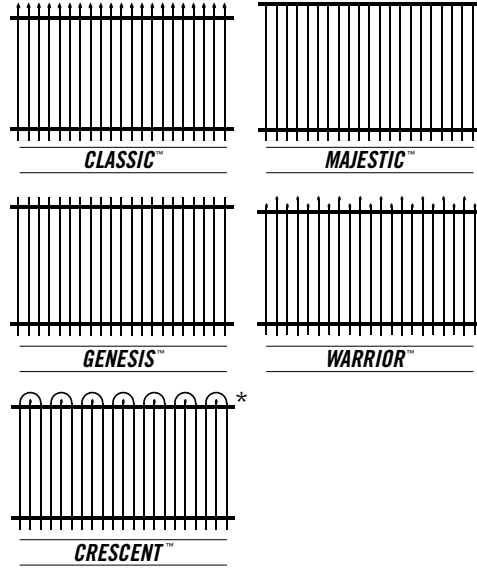

MONTAGE® | 2-RAIL PANELS | 3" AIR GAP

STANDARD BOTTOM | 8' PANEL LENGTH (94" actual width) | 26 PICKETS PER PANEL | 40 PANELS PER PALLET

PANEL	ITEM NUMBER	WEIGHT	STOCKING
3'	RM⊗234-3	34 lbs	⊙
3.5'	RM⊗240-3	38 lbs	⊙
4'	RM⊗246-3	44 lbs	⊙

⊗ = COLOR OPTIONS AVAILABLE | **B** = Black

⊙ = NON-STOCKED PRODUCT

For details, see Ameristar's Sales Policy in the catalog guide.

* Not Rackable panels.

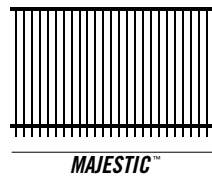

MONTAGE® | 2-RAIL PANELS | 4" AIR GAP

FLUSH BOTTOM | 8' PANEL LENGTH (94" actual width) | 21 PICKETS PER PANEL | 40 PANELS PER PALLET

PANEL	ITEM NUMBER	WEIGHT	STOCKING
3'	R☒Ⓞ234F	30 lbs	<u>MB</u>
3.5'	R☒Ⓞ240F	33 lbs	⊙
4'	R☒Ⓞ246F	36 lbs	<u>MB</u>
5'	R☒Ⓞ258F	43 lbs	⊙

☒ = FENCE STYLES AVAILABLE | C = Classic | M = Majestic | G = Genesis
W = Warrior | L = Crescent*

Ⓞ = COLOR OPTIONS AVAILABLE | B = Black

⊙ = NON-STOCKED PRODUCT

For details, see Ameristar's Sales Policy in the catalog guide.

Notes: Genesis panels are packaged with BLACK picket plugs.

* Not Rackable panels.

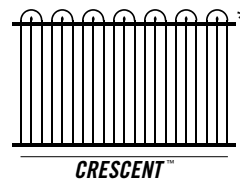
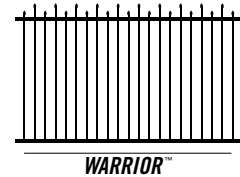
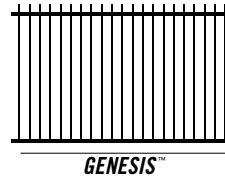
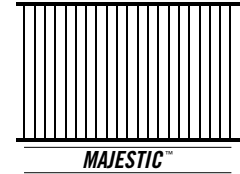
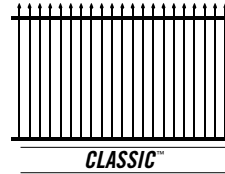

MONTAGE® | 2-RAIL PANELS | 3" AIR GAP

FLUSH BOTTOM | 8' PANEL LENGTH (94" actual width) | 26 PICKETS PER PANEL | 40 PANELS PER PALLET

PANEL	ITEM NUMBER	WEIGHT	STOCKING
3'	RMⓄ234F-3	34 lbs	⊙
3.5'	RMⓄ240F-3	38 lbs	⊙
4'	RMⓄ246F-3	44 lbs	⊙

Ⓞ = COLOR OPTIONS AVAILABLE | B = Black

⊙ = NON-STOCKED PRODUCT

For details, see Ameristar's Sales Policy in the catalog guide.

* Not Rackable panels.

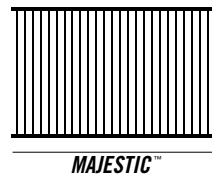

MONTAGE® | 3-RAIL PANELS | 4" AIR GAP

STANDARD BOTTOM | 8' PANEL LENGTH (94" actual width) | 21 PICKETS PER PANEL | 40 PANELS PER PALLET

PANEL	ITEM NUMBER	WEIGHT	STOCKING
3'	R☒☒334	35 lbs	MB
3.5'	R☒☒340	39 lbs	MB
4'	R☒☒346	42 lbs	CB MB GB MN
5'	R☒☒358	49 lbs	CB MB GB
6'	R☒☒370	55 lbs	CB MB GB

☒ = FENCE STYLES AVAILABLE | **C** = Classic **M** = Majestic **G** = Genesis
W = Warrior **L** = Crescent*

☒ = COLOR OPTIONS AVAILABLE | **B** = Black

⊙ = NON-STOCKED PRODUCT

For details, see Ameristar's Sales Policy in the catalog guide.

Notes: Genesis panels are packaged with BLACK picket plugs.

* Not Rackable panels.

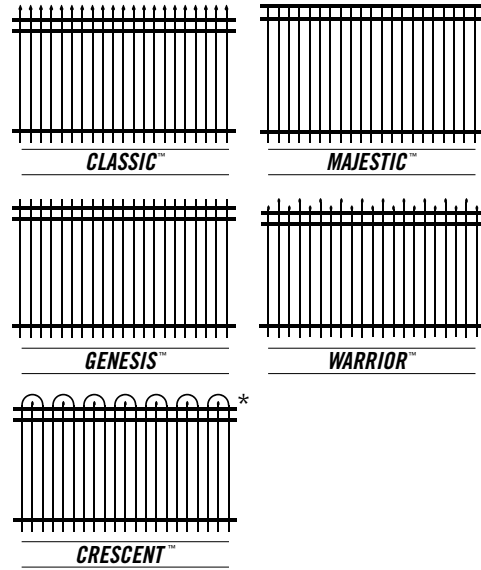

MONTAGE® | 3-RAIL PANELS | 3" AIR GAP

STANDARD BOTTOM | 8' PANEL LENGTH (94" actual width) | 26 PICKETS PER PANEL | 40 PANELS PER PALLET

PANEL	ITEM NUMBER	WEIGHT	STOCKING
3'	R☒☒334-3	40 lbs	⊙
3.5'	R☒☒340-3	44 lbs	⊙
4'	R☒☒346-3	50 lbs	MB
5'	R☒☒358-3	55 lbs	MB
6'	R☒☒370-3	62 lbs	⊙

☒ = FENCE STYLES AVAILABLE | **C** = Classic **M** = Majestic **G** = Genesis

☒ = COLOR OPTIONS AVAILABLE | **B** = Black

⊙ = NON-STOCKED PRODUCT

For details, see Ameristar's Sales Policy in the catalog guide.

* Not Rackable panels.

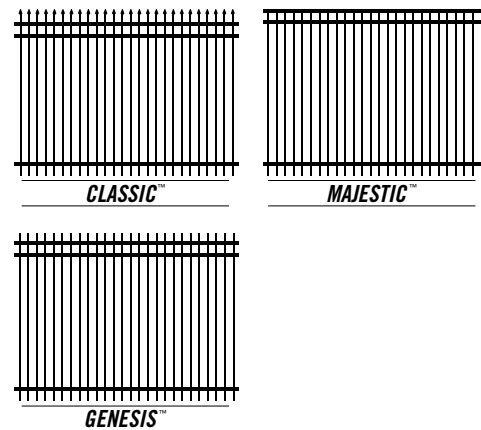

Effective: 05/01/24

MONTAGE® | 3-RAIL PANELS | 4" AIR GAP

FLUSH BOTTOM | 8' PANEL LENGTH (94" actual width) | 21 PICKETS PER PANEL | 40 PANELS PER PALLET

PANEL	ITEM NUMBER	WEIGHT	STOCKING
3'	R☒☒334F	35 lbs	☉
3.5'	R☒☒340F	39 lbs	☉
4'	R☒☒346F	42 lbs	MB
4.5'	RM ☒354F	48 lbs	MB
5'	R☒☒358F	49 lbs	MB
6'	R☒☒370F	55 lbs	☉

☒ = FENCE STYLES AVAILABLE | **C** = Classic **M** = Majestic **G** = Genesis
W = Warrior **L** = Crescent*

☒ = COLOR OPTIONS AVAILABLE | **B** = Black

☉ = NON-STOCKED PRODUCT
For details, see Ameristar's Sales Policy in the catalog guide.

Notes: Genesis panels are packaged with BLACK picket plugs.
* Not Rackable panels.

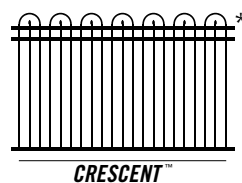
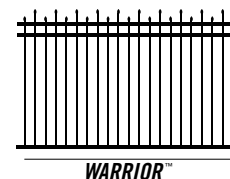
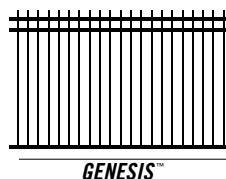
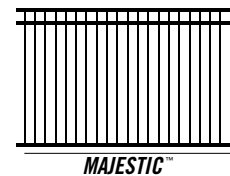
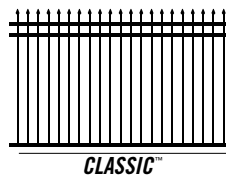

MONTAGE® | 3-RAIL PANELS | 3" AIR GAP

FLUSH BOTTOM | 8' PANEL LENGTH (94" actual width) | 26 PICKETS PER PANEL | 40 PANELS PER PALLET

PANEL	ITEM NUMBER	WEIGHT	STOCKING
3'	R☒☒334F-3	40 lbs	☉
3.5'	R☒☒340F-3	44 lbs	☉
4'	R☒☒346F-3	50 lbs	☉
4.5'	RM ☒354F-3	55 lbs	☉
5'	R☒☒358F-3	56 lbs	☉
6'	R☒☒370F-3	63 lbs	☉

☒ = FENCE STYLES AVAILABLE | **C** = Classic **M** = Majestic **G** = Genesis

☒ = COLOR OPTIONS AVAILABLE | **B** = Black

☉ = NON-STOCKED PRODUCT
For details, see Ameristar's Sales Policy in the catalog guide.

* Not Rackable panels.

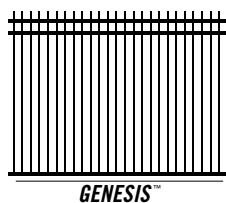
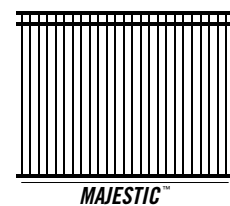
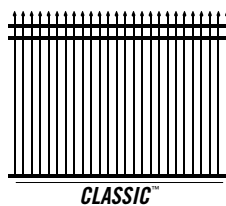

Effective: 05/01/2024

MONTAGE® | QUICK-FIT BRACKETS

AVAILABLE IN BAG QUANTITIES ONLY

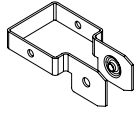

DESCRIPTION	ITEM NUMBER	BAG QTY	BOX QTY	WEIGHT
Universal Boulevard Bracket	B⊗102TR	2	48 bags	.37 lbs
<i>Bags packaged with: (2 Ea.) #B102TR Montage Universal Boulevard Bracket (2 Ea.) #1-0089-1 1/4"-20 x 1-1/4"L hex head trilobe 410SS (2 Ea.) #HX539 #10 x .75" stainless steel tek screws</i>				

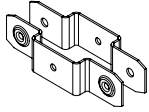

Line Bracket	B⊗104TR	2	60 bags	.68 lbs
<i>Bags packaged with: (2 Ea.) #B104ATR Montage Line Bracket with emboss (2 Ea.) #B104BTR Montage Line Bracket 4 Ea.) #1-0089-1 1/4"-20 x 1-14"L hex head trilobe 410 stainless steel (2 Ea.) #HX539 #10 x .75" stainless steel tek screws</i>				
<i>Use as a Boulevard Bracket around a 2" post to join two adjacent fence panels in-line.</i>				



Flat Mount Bracket	B⊗105TR	2	96 bags	.25 lbs
<i>Bags packaged with: (2 Ea.) #B105TR Montage Flat Mount Bracket (2 Ea.) #1-0089-1 1/4"-20 x 1-14"L hex head trilobe 410 stainless steel (2 Ea.) #HX524 #14 x .75" tek screws</i>				
<i>Use to attach fence panels to walls, wood posts, etc.</i>				

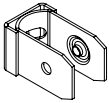

Swivel Bracket	B⊗106TR	2	60 bags	.39 lbs
<i>Bags packaged with: (2 Ea.) #B106ATR Montage Swivel Bracket Montage with emboss (2 Ea.) #B106BTR Montage Swivel Bracket Cup with emboss (2 Ea.) #HX541 1/4"-20 flange nut 18-8 stainless steel (2 Ea.) #2-0068 1/4"-20 x 2-1/2" carriage bolt 18-8 (2 Ea.) #1-0089-1 1/4"-20 x 1-1/4"L hex head trilobe 410 stainless steel (2 Ea.) #HX524 #14 x 3/4" Tek Screw</i>				
<i>Use for oblique angle intersections.</i>				

⊗ = COLOR OPTIONS AVAILABLE | B = Black

MONTAGE® | BRACKETS

AVAILABLE IN BAG QUANTITIES ONLY

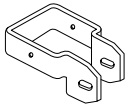

DESCRIPTION	ITEM NUMBER	BAG QTY	BOX QTY	WEIGHT
Universal Boulevard Bracket	B⊗102R	2	48 bags	.20 lbs
<i>Bags packaged with: (2 Ea.) #B102R-B Universal Boulevard Brackets (2 Ea.) #HB539 #10 x .75" stainless steel tek screws (2 Ea.) #HB511 .25" x 1.5" stainless steel carriage bolts (2 Ea.) #HB541 .25"-20 flange nuts 18-8</i>				

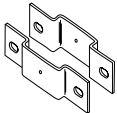

Line Bracket	B⊗104R	2	60 bags	.47 lbs
<i>Bags packaged with: (4 Ea.) #B104R-B Line Brackets (2 Ea.) #HB539 #10 x .75" stainless steel tek screws (4 Ea.) #HB511 .25" x 1.5" stainless steel carriage bolts (4 Ea.) #HB541 .25"-20 flange nuts 18-8</i>				
<i>Use as a Boulevard Bracket around a 2" post to join two adjacent fence panels in-line.</i>				

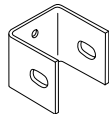

Flat Mount Bracket	B⊗105R	2	96 bags	.14 lbs
<i>Bags packaged with: (2 Ea.) #B105R-B Flat Mount Bracket (2 Ea.) #HB524 #14 x .75" tek screws #HB511 .25" x 1.5" stainless steel carriage bolts (2 Ea.) #HB541 .25"-20 flange nuts 18-8</i>				
<i>Use to attach fence panels to walls, wood posts, etc.</i>				

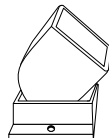

Swivel Bracket	B⊗106	2	60 bags	.20 lbs
<i>Bags packaged with: (2 Ea.) #B106-B Adjustable Aluminum Wall Mount Doghouse (2 Ea.) #B106P-B Adjustable Aluminum Wall Mount Plate (4 Ea.) #HB539 #10 x .75" stainless steel tek screws (2 Ea.) #HB519 #10 x .625" Tek Screws 18-8</i>				
<i>Use for oblique angle intersections.</i>				

⊗ = COLOR OPTIONS AVAILABLE | B = Black

Effective: 05/01/24

MONTAGE® | FINIALS & ADORNMENTS

FINIALS & PICKET PLUGS FOR GENESIS PANELS ONLY



QUAD FLARE

.590" / .2 lbs
A⊗ 301R1



TRIAD

.590" / .2 lbs
A⊗ 302R1



ROYALTY

.590" / .2 lbs
A⊗ 303R1

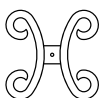

BUTTERFLY SCROLL

.590" / .2 lbs
H⊗ 058NR1



DOUBLE RINGS

.590" / .7 lbs
A⊗ 102

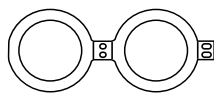

CORONA

.590" / .35 lbs
A⊗ 103*



SERPENTINE SCROLL

.590" / .75 lbs
H⊗ 059

.590" PRESS FIT PICKET FINIALS

» 21 finials required per panel with 4" air-space

» 26 finials required per panel with a 3" air-space

* Picket plugs in bag quantities only / 21 plugs per bag

⊗ = **COLOR OPTIONS AVAILABLE** | **B** = Black

NOTE: Picket plugs are available in bag quantities only / 21 plugs per bag; Item number = AB502

MONTAGE PANEL ADORNMENTS

» Fit in between / on the face of top rails on 3-rail panels

» #10 self-drilling screws included

» 11 adornments required per panel

» Die cast aluminum / Corona pressed steel*

⊗ = **COLOR OPTIONS AVAILABLE** | **B** = Black

MONTAGE® | FASTENERS

AVAILABLE IN BAG QUANTITIES ONLY (Phillips head screws sold individually)



DESCRIPTION

#14 x .75" Tek Screw

ITEM NUMBER / BLACK

H⊗524P-50

BAG QTY

50

Steel hex head self-drilling screws for attaching Montage brackets & adornments

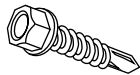

#10 x .75" Tek Screw

H⊗539P-50

50

Steel hex head self-drilling screws for attaching Montage brackets & adornments

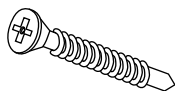

#10 x .625" Phillips Head Tek Screw

H⊗519P

1

Steel flat head screws for setting angle on Montage swivel brackets

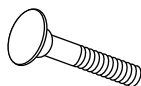

.25" x 1.5" Carriage Bolt

H⊗511P-20

20

Steel carriage bolts for Montage brackets



.25" Flange Nuts

H⊗541P-20

20

Steel flange nuts for attaching Montage brackets

⊗ = **COLOR OPTIONS AVAILABLE** | **B** = Black

Effective: 05/01/2024

MONTAGE® | CUSTOM FINISHES

WARRANTY ON CUT COMPONENTS VOID WITHOUT PROPER TOUCH-UP APPLICATION*

*For details & the guidelines for the proper 3-step process, see Ameristar's Sales Policy in the catalog guide

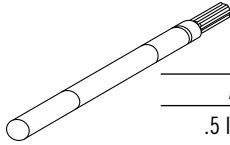

PAINT PEN

.5 lbs / P⊗100

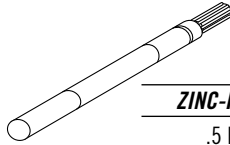

ZINC-RICH PAINT PEN

.5 lbs / PZ100

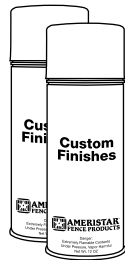

SPRAY PAINT

1.1 lbs / F⊗100

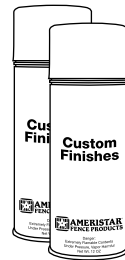

ZINC-RICH PRIMER

1.1 lbs / FZ100

⊗ = COLOR OPTIONS AVAILABLE | B = Black

Effective: 05/01/24

MONTAGE® | POSTS, BASES & CAPS

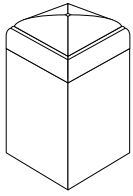

STEEL POSTS

2"sq. x 16ga.

2.5"sq. x 16ga.

POST LENGTH	ITEM NUMBER	WEIGHT
4' 9"	WP⊗ 20057	8 lbs
5' 3"	WP⊗ 20063	9 lbs
5' 9"	WP⊗ 20069	10 lbs
6' 9"	WP⊗ 20081	11 lbs
7' 9"	WP⊗ 20093	13 lbs
8' 9"	WP⊗ 20105	14 lbs
6'	WP⊗ 25072	12 lbs
7'	WP⊗ 25084	14 lbs
8'	WP⊗ 25096	16 lbs
9'	WP⊗ 25108	18 lbs

NOTE: When installed in locations subject to freezing temperatures, where posts are grouted into core-drilled holes, a .25" hole must be drilled into the post approximately .5" above the elevation. This allows for proper drainage of ground water build-up. The drilled hole must be clean & dry prior to applying zinc primer & color finish. Failure to follow these practices voids the warranty of the fence system.

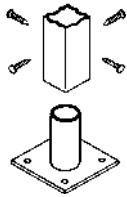

POST BASE

Fits 2"sq post

BASE SIZE	ITEM NUMBER	DRILL HOLES	WEIGHT
5" x 5"	B⊗ 205	.5625"	3 lbs

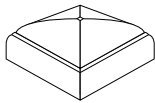

STANDARD FLAT CAP

Steel

CAP SIZE	ITEM NUMBER	WEIGHT
1.25"sq.	A⊗ 503	.1 lbs
1.75"sq.	A⊗ 505	.2 lbs
2"sq.	A⊗ 506	.3 lbs
2.5"sq.	A⊗ 507	.4 lbs



BALL CAP

Aluminum

CAP SIZE	ITEM NUMBER	WEIGHT
2"sq.	H⊗ 508R	.7 lbs
2.5"sq.	A⊗ 513R1	.7 lbs

⊗ = COLOR OPTIONS AVAILABLE | B = Black

Effective: 05/01/2024

Effective: 05/01/24

MONTAGE® | LIFETIME LIMITED WARRANTY

WELDED ORNAMENTAL STEEL FENCE

Ameristar's Montage® residential grade welded ornamental steel fence is manufactured from the highest quality materials by skilled craftsmen to meet the highest standards of workmanship in the industry. Galvanized steel framework is subjected to a multi-stage pretreatment/wash, followed by a duplex cathodic electro-coat system consisting of an epoxy primer, which significantly increases corrosion protection, and an acrylic liquid topcoat, which provides the protection necessary to withstand adverse weathering effects. The electro-coated surface on all Montage residential grade welded ornamental steel panels and posts are guaranteed under a limited lifetime warranty under normal and intended usage, against cracking, peeling, chipping, blistering and corrosion resulting in structural failure, without cause. Ameristar Montage residential grade welded ornamental fences are also guaranteed against defects in workmanship or materials. Normal and intended usage does not include physical damage, abrasion, or heavy salt spray exposure to the protective coating or loss of gloss. Warranty does not apply to any non-residential application. Lifetime limited warranty does not apply to Montage residential gates, all gates are warranted for a period of 1-year from the date of installation. Lifetime limited warranty does not apply to installations within 1 mile of salt-water coastline. Installations located less than 1 mile from coastline will be subject to a 5-year pro-rated manufacturer's warranty.

THE FOLLOWING ACTS AND/OR OMISSIONS WILL VOID THE SUBJECT WARRANTY:

- Damage to the product caused by the property owner by use of landscape, gardening equipment, chemicals that may cause damage, water sprinklers with high mineral content and/or greywater/reclaimed water;
- Damage caused by adhesion of chicken wire, chain link mesh, welded wire, or other similar substance to the product;
- Damage caused by allowing plant life of any sort to grow directly upon or in contact with any portion of the product or sap from trees;
- Any alteration to the product itself by the property owner including any on-site cutting or welding; and/or, failure to follow any and all instructions provided by Ameristar at the time of sale to the original purchaser even if these instructions are not forwarded to the ultimate claimant under this warranty.
- When cutting and/or drilling the Montage fence system components, immediately seal the exposed surfaces by 1) Removing all metal shavings from the cut area, 2) Applying zinc-rich primer to thoroughly cover cut edge and drilled hole and, after letting dry, 3) Applying two (2) coats of custom finish spray paint matching fence color. Failure to seal exposed surfaces per steps 1-3 above will negate warranty.
- If contractor uses non-Ameristar parts/components, this will negate the warranty.

Should any Montage residential grade welded ornamental steel panel or post manufactured by Ameristar fail in accordance with any of the above conditions, Ameristar warrants to the homeowner (individual retaining the original proof of purchase) their redemption through replacement or settlement. The choice of redemption method is solely at the discretion of Ameristar.

Notice of failure under the conditions of this warranty shall be submitted via warranty claim form located at the following link (<https://bit.ly/MontageWarrantyClaim>). Form shall be submitted with all required information, original proof of purchase, description specifying the nature of defect and photographs of fence and site conditions. Should the fence be improperly installed, Ameristar shall not be responsible for guaranteed performance or appearance of the material. Neither does this guarantee apply when failure or damage is due to improper use or application, abuse or misuse, salt spray exposure, vandalism, or acts of God. Ameristar reserves the right to inspect the material to determine validity of the claim.

Upon acceptance of the claim by Ameristar or its authorized representative, redemption by replacement or settlement shall be made by Ameristar. Reimbursement for labor necessary to restore and/or replace components that have been found defective under the terms of this warranty is guaranteed to the homeowner (individual retaining the original proof of purchase) for a period of five (5) years from the original purchase date. Ameristar reserves the right to select the qualified company or individual to perform the labor to repair or replace the components that are deemed defective under the terms of this warranty.

The above constitutes the complete warranty by the manufacturer. No other agreement, written or implied, is valid. Ameristar does not authorize any other person or agent to make any other express warranties. Ameristar neither assumes nor authorizes any other person or agent to assume any other liability in connection with the Montage residential grade welded ornamental steel fence system.

Effective: 05/01/2024

MONTAGE® | CONSTRUCTION SPECIFICATION 32 31 19

STEEL ORNAMENTAL FENCE SYSTEM – FUSION WELDED

PART 1 - GENERAL

1.01 WORK INCLUDED

The contractor shall provide all labor, materials and appurtenances necessary for installation of the welded ornamental steel fence system defined herein at (specify project site).

1.02 RELATED WORK

Section _____ - Earthwork

Section _____ - Concrete

1.03 SYSTEM DESCRIPTION

The manufacturer shall supply a total fence system of (specify Montage® standard picket space or Montage Pool, Pet & Play® 3" air space) Welded and Rackable (ATF – All Terrain Flexibility) Ornamental Steel, (for standard picket space, specify Classic™, Majestic™, Genesis™, Warrior™, Crescent™; for 3" air-space specify Classic, Majestic, or Genesis™) design. The system shall include all components (i.e., panels, posts, gates and hardware) required.

1.04 QUALITY ASSURANCE

The contractor shall provide laborers and supervisors who are thoroughly familiar with the type of construction involved and materials and techniques specified.

1.05 REFERENCES

- **ASTM A653/A653M** – Standard Specification for Steel Sheet, Zinc-Coated (Galvanized) or Zinc-Iron Alloy Coated (Galvannealed) by the Hot-Dip Process
- **ASTM B117** – Practice for Operating Salt-Spray (Fog) Apparatus
- **ASTM D523** – Test Method for Specular Gloss
- **ASTM D714** – Test Method for Evaluating Degree of Blistering in Paint
- **ASTM D1654** – Test Method for Evaluation of Painted or Coated Specimens Subjected to Corrosive Environments
- **ASTM D2244** – Test Method for Calculation of Color Differences from Instrumentally Measured Color Coordinates
- **ASTM D2794** – Test Method for Resistance of Organic Coatings to the Effects of Rapid Deformation (Impact)
- **ASTM D3359** – Test Method for Measuring Adhesion by Tape Test
- **ASTM D6695** - Standard Practice for Xenon-Arc Exposures of Paint and Related Coatings
- **ASTM F2408** – Ornamental Fences Employing Galvanized Steel Tubular Pickets

1.06 SUBMITTAL

The manufacturer's literature shall be submitted prior to installation.

1.07 PRODUCT HANDLING AND STORAGE

Upon receipt at the job site, all materials shall be checked to ensure that no damage occurred during shipping or handling. Materials shall be stored in such a manner to ensure proper ventilation and drainage, and to protect against damage, weather, vandalism and theft.

1.08 PRODUCT WARRANTY

- All structural fence components (i.e., rails, pickets, and posts) shall be warranted within specified limitations by the manufacturer for a period of 20 years from date of original purchase. Warranty shall cover any defects in material finish, including cracking, peeling, chipping, blistering or corroding.
- Reimbursement for labor necessary to restore or replace components that have been found to be defective under the terms of manufacturer's warranty shall be guaranteed for five (5) years from date of original purchase.

PART 2 - MATERIALS

2.01 MANUFACTURER

The fence system shall conform to (specify Montage standard picket space or Montage Pool, Pet & Play 3" air space) Welded and Rackable (ATF – All Terrain Flexibility) Ornamental Steel, (for standard picket space, specify Classic, Majestic, Genesis, Warrior, Crescent; for 3" air-space specify Classic, Majestic, or Genesis) design, (specify extended picket or flush) bottom rail treatment, (specify 2-Rail or 3-Rail) style manufactured by Ameristar Fence Products, Inc. in Tulsa, Oklahoma.

2.02 MATERIAL

- Steel material for fence panels and posts shall conform to the requirements of **ASTM A653/A653M**, with a minimum yield strength of 45,000 psi (310 MPa) and a minimum zinc (hot-dip galvanized) coating weight of 0.60 oz/ft² (184 g/m²), Coating Designation G-60.
- Material for pickets shall be 5/8" square x 18 Ga. tubing. The rails shall be steel channel, 1.25" x 0.92" x 14 Ga. Picket holes in the rail shall be spaced (specify 4.334" o.c. for standard picket space or 3.500" o.c. for 3" air space). Fence posts shall be a minimum of 2" square x 16 Ga. Gate posts shall meet the minimum requirements of **Table 1**.

2.03 FABRICATION

- Pickets, rails and posts shall be pre-cut to specified lengths. Rails shall be pre-punched to accept pickets.
- Pickets shall be inserted into the pre-punched holes in the rails and shall be aligned to standard spacing using a specially calibrated alignment fixture. The aligned pickets and rails shall be joined at each picket-to-rail intersection by Ameristar's proprietary fusion welding process, thus completing the rigid panel assembly (Note: The process produces a virtually seamless, spatter-free good-neighbor appearance, equally attractive from either side of the panel).
- The manufactured panels and posts shall be subjected to an inline electrode position coating (E-Coat) process consisting of a multi-stage pretreatment/wash, followed by a duplex application of an epoxy primer and an acrylic topcoat. The minimum cumulative coating thickness of epoxy and acrylic shall be 2 mils (0.058 mm). The color shall be Black. The coated panels and posts shall be capable of meeting the performance requirements for each quality characteristic shown in **Table 2** (Note: The requirements in Table 2 meet or exceed the coating performance criteria of **ASTM F2408**).
- The manufactured fence system shall be capable of meeting the vertical load, horizontal load, and infill performance requirements for Residential weight fences under **ASTM F2408**.
- Gates shall be fabricated using welded ornamental panel material and gate ends having a 1.25" square cross-sectional size. All rail and upright intersections shall be joined by welding. All picket and rail intersections shall also be joined by welding.

PART 3 - EXECUTION

3.01 PREPARATION

All new installation shall be laid out by the contractor in accordance with the construction plans.

3.02 FENCE INSTALLATION

Fence post shall be spaced according to **Table 3**, plus or minus .5". For installations that must be raked to follow sloping grades, the post spacing dimension must be measured along the grade. Fence panels shall be attached to posts with brackets supplied by the manufacturer. The "Earthwork" and "Concrete" sections of this specification shall govern material requirements for the concrete footer.

Effective: 05/01/24

MONTAGE® | CONSTRUCTION SPECIFICATION 32 31 19

STEEL ORNAMENTAL FENCE SYSTEM – FUSION WELDED

3.03 FENCE INSTALLATION MAINTENANCE

When cutting/drilling rails or posts adhere to the following steps to seal the exposed steel surfaces; 1) Remove all metal shavings from cut area. 2) Apply zinc-rich primer to thoroughly cover cut edge and/or drilled hole; let dry. 3) Apply 2 coats of custom finish paint matching fence color. Failure to seal exposed surfaces per steps 1-3 above will negate warranty. Ameristar spray cans or paint pens shall be used to prime and finish exposed surfaces; it is recommended that paint pens be used to prevent overspray. Use of non-Ameristar parts or components will negate the manufacturer's warranty.

3.04 GATE INSTALLATION

Gate posts shall be spaced according to the manufacturer's gate drawings, dependent on standard out-to-out gate leaf dimensions and gate hardware selected. Type and quantity of gate hinges shall be based on the application; weight, height, and number of gate cycles. The manufacturer's gate drawings shall identify the necessary gate hardware required for the application. Gate hardware shall be provided by the manufacturer of the gate and shall be installed per manufacturer's recommendations.

3.05 CLEANING

The contractor shall clean the jobsite of excess materials; post-hole excavations shall be scattered uniformly away from posts.

TABLE 1 MINIMUM SIZES FOR MONTAGE POSTS

GATE LEAF	GATE HEIGHT	
	up to & including 4' height	over 4', up to & including 6' height
up to 4'	2" x 16 gauge	2" x 16 gauge
4'1" to 6'	2" x 16 gauge	2.5" x 16 gauge
6'1" to 8'	2.5" x 16 gauge	2.5" x 16 gauge

Note: For gates constructed with panic and kick tubes or plates, it is recommended to move up to the next post size.

TABLE 2 COATING PERFORMANCE REQUIREMENTS

QUALITY CHARACTERISTICS	ASTM TEST METHOD	PERFORMANCE REQUIREMENTS
ADHESION	D3359 – METHOD B	Adhesion (retention of coating) over 90% of test area (tape and knife kit test).
CORROSION RESISTANCE	B117, D714, D1654	Corrosion resistance over 1,000 hours (scribed per D1654; failure mode is accumulation of 1/8" coating loss from scribe or medium #8 blisters)
IMPACT RESISTANCE	D2794	Impact resistance over 60" lb. (forward impact using 0.625" ball).
WEATHERING RESISTANCE	D822 D2244, D523 (60° method)	Weathering resistance over 1,000 hours (failure mode is 60% loss of gloss or color variance of more than 3 delta-E color units).

TABLE 3 MONTAGE POST SPACING BY BRACKET TYPE

SPAN	Classic, Genesis, Majestic, Warrior, & Crescent / 8' nominal (94" rail)			
POST SIZE	2"	2"	2"	2"
BRACKET TYPE	Montage Universal (BB102)	Montage Line Blvd. (BB104)	Montage Flat Mount (BB105)	Montage Swivel (BB106)*
POST SETTINGS ± .5" O.C.	96.75"	96.75"	96.75"	*96.75"

* When using BB106 swivel brackets on either or both ends of a panel installation, care must be taken to ensure the spacing between post and adjoining pickets meets applicable codes. This will require trimming one or both ends of the panel.

Effective: 05/01/2024

MONTAGE® | SINGLE SWING GATE SPECIFICATIONS

1.25"sq x 16ga GATE ENDS | .9375"w x 1.25"h x 14ga RAILS | .590"sq x 18ga PICKETS

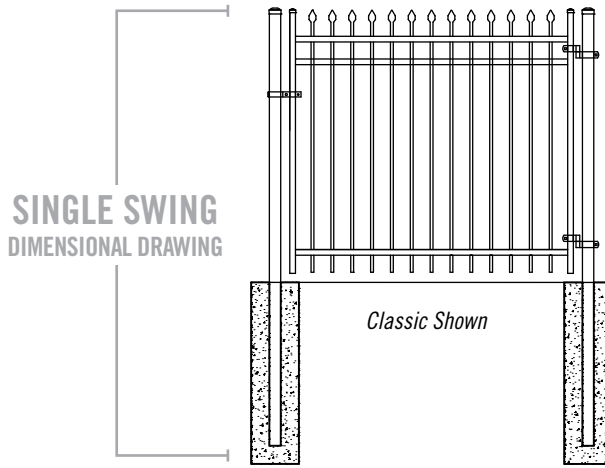

SINGLE SWING HARDWARE KITS & POST INTERSPACES

OPENING	LEAF WIDTH*	D&D GATE HARDWARE KIT			D&D POOL GATE HARDWARE KIT			SGBS2 BOLT ON HINGE KIT		
		HC	LC	P _S	HC	LC	P _S	HC	LC	P _S
3.5'	36.5"	1.125"	.75"	38.375"	1.125"	.75"	38.375"	2"	2"	40.5"
4'	45"	1.125"	.75"	46.875"	1.125"	.75"	46.875"	2"	2"	49"
5'	62.5"	1.125"	.75"	64.375"	1.125"	.75"	64.375"	2"	2"	66.5"
6'	71"	1.125"	.75"	72.875"	1.125"	.75"	72.875"	2"	2"	75"
7'	79.75"	1.125"	.75"	81.625"	1.125"	.75"	81.625"	2"	2"	83.75"
8'	96.5"	1.125"	.75"	98.375"	1.125"	.75"	98.375"	2"	2"	100.5"

W = width* | HC = hinge clearance | LC = latch clearance | P_S = gate post spacing**
 * From outside to outside | ** From inside to inside

NOTE: GATE HARDWARE SOLD SEPARATELY. SEE ORNAMENTAL GATE HARDWARE SECTION FOR MORE DETAILS.

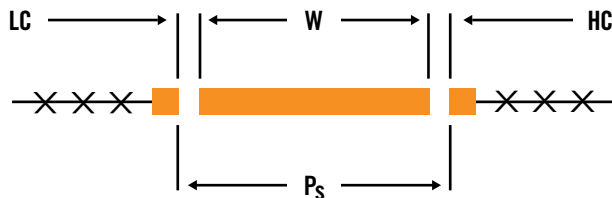

Effective: 05/01/24

MONTAGE® | DOUBLE SWING GATE SPECIFICATIONS

1.25"sq x 16ga GATE ENDS | .9375"w x 1.25"h x 14ga RAILS | .590"sq x 18ga PICKETS

DOUBLE SWING
DIMENSIONAL DRAWING

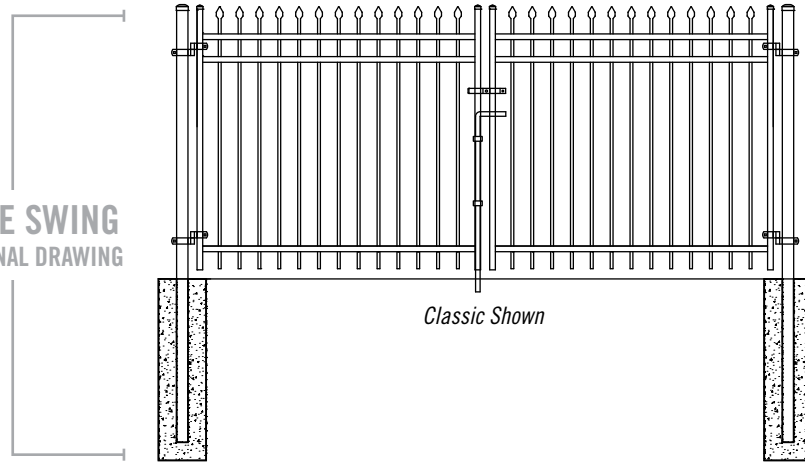

DOUBLE SWING
HARDWARE KITS &
POST INTERSPACES

OPENING	LEAF WIDTH*	D&D GATE HARDWARE KIT			SGBD2 BOLT ON HINGE KIT		
		HC	LC	P _d	HC	LC	P _d
7'	36.5"	.75"	.75"	75.25"	2"	2"	79.00"
8'	45"	.75"	.75"	92.25"	2"	2"	96.00"
10'	62.5"	.75"	.75"	127.25"	2"	2"	131.00"
12'	71"	.75"	.75"	144.25"	2"	2"	148.00"
14'	79.75"	.75"	.75"	161.75"	2"	2"	165.50"
16'	96.5"	.75"	.75"	195.25"	2"	2"	199.00"

W = width (x2)* | HC = hinge clearance (x2) | LC = latch clearance | P_d = gate post spacing**
 * From outside to outside | ** From inside to inside

NOTE: GATE HARDWARE SOLD SEPARATELY. SEE ORNAMENTAL GATE HARDWARE SECTION FOR MORE DETAILS.

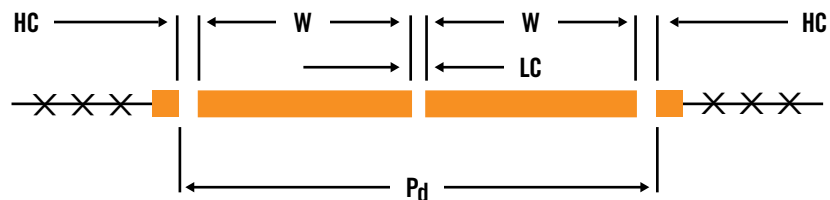

Effective: 05/01/2024

MONTAGE® | 2-RAIL SINGLE SWING GATES

4" AIR GAP | STANDARD BOTTOM | GATE HARDWARE SOLD SEPARATELY

	OPENING	LEAF WIDTH	ITEM NUMBER	PICKET QTY	WEIGHT	STOCKING
3' HEIGHT	3.5'	36.5"	W☒⊗234-42*	7	17 lbs	☉
	4'	45"	W☒⊗234-48	9	20 lbs	☉
	5'	62.5"	W☒⊗234-60*	13	25 lbs	☉
	6'	71"	W☒⊗234-72	15	28 lbs	☉
	7'	79.75"	W☒⊗234-84	17†	31 lbs	☉
3.5' HEIGHT	3.5'	36.5"	W☒⊗240-42*	7	19 lbs	☉
	4'	45"	W☒⊗240-48	9	22 lbs	☉
	5'	62.5"	W☒⊗240-60*	13	29 lbs	☉
	6'	71"	W☒⊗240-72	15	32 lbs	☉
	7'	79.75"	W☒⊗240-84	17†	35 lbs	☉
4' HEIGHT	3.5'	36.5"	W☒⊗246-42*	7	24 lbs	☉
	4'	45"	W☒⊗246-48	9	25 lbs	CB MB GB
	5'	62.5"	W☒⊗246-60*	13	32 lbs	CB MB GB
	6'	71"	W☒⊗246-72	15	35 lbs	CB MB
	7'	79.75"	W☒⊗246-84	17†	39 lbs	☉
5' HEIGHT	3.5'	36.5"	W☒⊗258-42*	7	29 lbs	☉
	4'	45"	W☒⊗258-48	9	30 lbs	CB MB GB
	5'	62.5"	W☒⊗258-60*	13	36 lbs	CB MB
	6'	71"	W☒⊗258-72	15	42 lbs	☉
	7'	79.75"	W☒⊗258-84	17†	46 lbs	☉
	8'	96.5"	W☒⊗258-96	21	55 lbs	☉

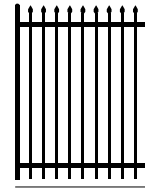

CLASSIC™

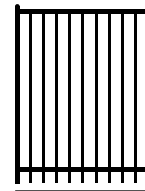

MAJESTIC™

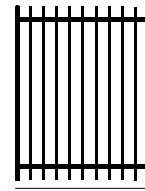

GENESIS™

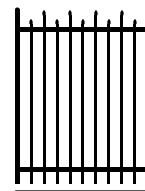

WARRIOR™

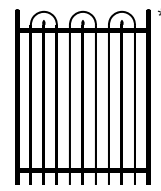

CRESCENT™

☒ = FENCE STYLES AVAILABLE | **C** = Classic | **M** = Majestic | **G** = Genesis | **W** = Warrior | **L** = Crescent*

⊗ = COLOR OPTIONS AVAILABLE | **B** = Black

☉ = NON-STOCKED PRODUCT | For details, see Ameristar's Sales Policy in the catalog guide.

*Not available in Crescent for 3.5' or 5' gate openings | †18 pickets per gate leaf in Crescent

Notes: Gate heights are nominal & gate widths are actual. Gate hardware sold separately.
 See Ornamental Gate Hardware section for more details.

Effective: 05/01/24

MONTAGE® | 2-RAIL DOUBLE SWING GATES

4" AIR GAP | STANDARD BOTTOM | GATE HARDWARE SOLD SEPARATELY

	OPENING	LEAF WIDTH	ITEM NUMBER	PICKET QTY	WEIGHT	STOCKING
3' HEIGHT	7'	36.5"	W☒Ⓞ234-84D*	7	38 lbs	☉
	8'	45"	W☒Ⓞ234-96D	9	44 lbs	☉
	10'	62.5"	W☒Ⓞ234-120D*	13	54 lbs	☉
	12'	71"	W☒Ⓞ234-144D	15	60 lbs	☉
	14'	79.75"	W☒Ⓞ234-168D	17†	68 lbs	☉
	16'	96.5"	W☒Ⓞ234-192D	21	72 lbs	☉
3.5' HEIGHT	7'	36.5"	W☒Ⓞ240-84D*	7	42 lbs	☉
	8'	45"	W☒Ⓞ240-96D	9	48 lbs	☉
	10'	62.5"	W☒Ⓞ240-120D*	13	62 lbs	☉
	12'	71"	W☒Ⓞ240-144D	15	68 lbs	☉
	14'	79.75"	W☒Ⓞ240-168D	17†	76 lbs	☉
	16'	96.5"	W☒Ⓞ240-192D	21	82 lbs	☉
4' HEIGHT	7'	36.5"	W☒Ⓞ246-84D*	7	50 lbs	☉
	8'	45"	W☒Ⓞ246-96D	9	54 lbs	CB MB GB
	10'	62.5"	W☒Ⓞ246-120D*	13	64 lbs	CB MB GB
	12'	71"	W☒Ⓞ246-144D	15	74 lbs	CB MB
	14'	79.75"	W☒Ⓞ246-168D	17†	84 lbs	☉
	16'	96.5"	W☒Ⓞ246-192D	21	92 lbs	☉
5' HEIGHT	7'	36.5"	W☒Ⓞ258-84D*	7	60 lbs	☉
	8'	45"	W☒Ⓞ258-96D	9	64 lbs	CB MB GB
	10'	62.5"	W☒Ⓞ258-120D*	13	76 lbs	CB MB
	12'	71"	W☒Ⓞ258-144D	15	88 lbs	☉
	14'	79.75"	W☒Ⓞ258-168D	17†	98 lbs	☉
	16'	96.5"	W☒Ⓞ258-192D	21	110 lbs	☉

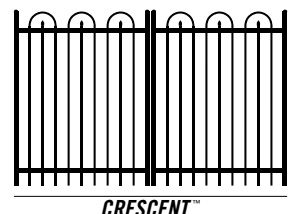
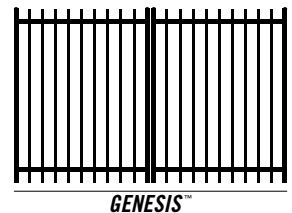
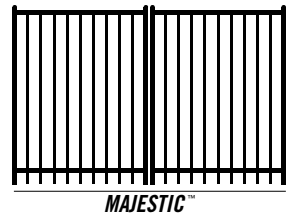
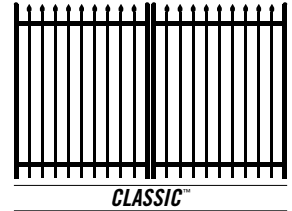

☒ = FENCE STYLES AVAILABLE | **C** = Classic **M** = Majestic **G** = Genesis **W** = Warrior **L** = Crescent*

Ⓞ = COLOR OPTIONS AVAILABLE | **B** = Black

☉ = NON-STOCKED PRODUCT | For details, see Ameristar's Sales Policy in the catalog guide.

*Not available in Crescent for 7' or 10' gate openings | †18 pickets per gate leaf in Crescent

Notes: Two gate leaves included for double all gates. Gate heights are nominal & gate widths are actual. Gate hardware sold separately. See Ornamental Gate Hardware section for more details.

Effective: 05/01/2024

MONTAGE® | 2-RAIL SINGLE SWING GATES

3" AIR GAP | STANDARD BOTTOM | GATE HARDWARE SOLD SEPARATELY

	OPENING	LEAF WIDTH	ITEM NUMBER	PICKET QTY	WEIGHT	STOCKING
3' HEIGHT	3.5'	36.5"	RM ⊗234-42	9	17 lbs	⊙
	4'	45"	RM ⊗234-48	11	21 lbs	⊙
	5'	62.5"	RM ⊗234-60	16	27 lbs	⊙
	6'	71"	RM ⊗234-72	19	32 lbs	⊙
	7'	79.75"	RM ⊗234-84	21	39 lbs	⊙
	8'	96.5"	RM ⊗234-96	26	42 lbs	⊙
3.5' HEIGHT	3.5'	36.5"	RM ⊗240-42	9	21 lbs	⊙
	4'	45"	RM ⊗240-48	11	24 lbs	⊙
	5'	62.5"	RM ⊗240-60	16	31 lbs	⊙
	6'	71"	RM ⊗240-72	19	36 lbs	⊙
	7'	79.75"	RM ⊗240-84	21	41 lbs	⊙
	8'	96.5"	RM ⊗240-96	26	45 lbs	⊙
4' HEIGHT	3.5'	36.5"	RM ⊗246-42	9	25 lbs	⊙
	4'	45"	RM ⊗246-48	11	28 lbs	⊙
	5'	62.5"	RM ⊗246-60	16	34 lbs	⊙
	6'	71"	RM ⊗246-72	19	40 lbs	⊙
	7'	79.75"	RM ⊗246-84	21	44 lbs	⊙
	8'	96.5"	RM ⊗246-96	26	52 lbs	⊙

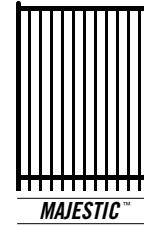

⊗ = **COLOR OPTIONS AVAILABLE** | **B** = Black

⊙ = **NON-STOCKED PRODUCT** | For details, see Ameristar's Sales Policy in the catalog guide.

Notes: Gate heights are nominal & gate widths are actual. Gate hardware sold separately. See Ornamental Gate Hardware section for more details.

Effective: 05/01/24

MONTAGE® | 2-RAIL DOUBLE SWING GATES

3" AIR GAP | STANDARD BOTTOM | GATE HARDWARE SOLD SEPARATELY

	OPENING	LEAF WIDTH	ITEM NUMBER	PICKET QTY	WEIGHT	STOCKING
3' HEIGHT	7'	36.5"	RM ⊗234-84D	9	42 lbs	⊙
	8'	45"	RM ⊗234-96D	11	46 lbs	⊙
	10'	62.5"	RM ⊗234-120D	16	58 lbs	⊙
	12'	71"	RM ⊗234-144D	19	68 lbs	⊙
	14'	79.75"	RM ⊗234-168D	21	68 lbs	⊙
	16'	96.5"	RM ⊗234-192D	26	80 lbs	⊙
3.5' HEIGHT	7'	36.5"	RM ⊗240-84D	9	46 lbs	⊙
	8'	45"	RM ⊗240-96D	11	52 lbs	⊙
	10'	62.5"	RM ⊗240-120D	16	66 lbs	⊙
	12'	71"	RM ⊗240-144D	19	76 lbs	⊙
	14'	79.75"	RM ⊗240-168D	21	78 lbs	⊙
	16'	96.5"	RM ⊗240-192D	26	90 lbs	⊙
4' HEIGHT	7'	36.5"	RM ⊗246-84D	9	54 lbs	⊙
	8'	45"	RM ⊗246-96D	11	60 lbs	⊙
	10'	62.5"	RM ⊗246-120D	16	72 lbs	⊙
	12'	71"	RM ⊗246-144D	19	84 lbs	⊙
	14'	79.75"	RM ⊗246-168D	21	88 lbs	⊙
	16'	96.5"	RM ⊗246-192D	26	104 lbs	⊙

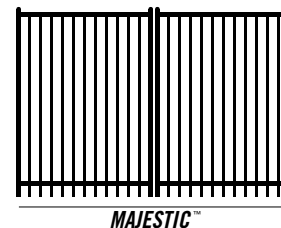

⊗ = COLOR OPTIONS AVAILABLE | B = Black

⊙ = NON-STOCKED PRODUCT | For details, see Ameristar's Sales Policy in the catalog guide.

Notes: Two gate leaves included for double all gates. Gate heights are nominal & gate widths are actual. Gate hardware sold separately. See Ornamental Gate Hardware section for more details.

Effective: 05/01/2024

TO PLACE YOUR ORDER CALL 888-333-3422 | VISIT AMERISTARPERIMETER.COM |

AMERISTAR
ASSA ABLOY

MONTAGE® | 2-RAIL SINGLE SWING GATES

4" AIR GAP | FLUSH BOTTOM | GATE HARDWARE SOLD SEPARATELY

	OPENING	LEAF WIDTH	ITEM NUMBER	PICKET QTY	WEIGHT	STOCKING
3' HEIGHT	3.5'	36.5"	W☒Ⓞ234F-42*	7	17 lbs	☉
	4'	45"	W☒Ⓞ234F-48	9	21 lbs	☉
	5'	62.5"	W☒Ⓞ234F-60*	13	25 lbs	☉
	6'	71"	W☒Ⓞ234F-72	15	28 lbs	☉
	7'	79.75"	W☒Ⓞ234F-84	17†	31 lbs	☉
3.5' HEIGHT	3.5'	36.5"	W☒Ⓞ240F-42*	7	20 lbs	☉
	4'	45"	W☒Ⓞ240F-48	9	22 lbs	☉
	5'	62.5"	W☒Ⓞ240F-60*	13	29 lbs	☉
	6'	71"	W☒Ⓞ240F-72	15	32 lbs	☉
	7'	79.75"	W☒Ⓞ240F-84	17†	35 lbs	☉
4' HEIGHT	3.5'	36.5"	W☒Ⓞ246F-42*	7	23 lbs	☉
	4'	45"	W☒Ⓞ246F-48	9	25 lbs	MB
	5'	62.5"	W☒Ⓞ246F-60*	13	32 lbs	MB
	6'	71"	W☒Ⓞ246F-72	15	35 lbs	☉
	7'	79.75"	W☒Ⓞ246F-84	17†	39 lbs	☉
5' HEIGHT	3.5'	36.5"	W☒Ⓞ258F-42*	7	29 lbs	☉
	4'	45"	W☒Ⓞ258F-48	9	30 lbs	MB
	5'	62.5"	W☒Ⓞ258F-60*	13	36 lbs	☉
	6'	71"	W☒Ⓞ258F-72	15	42 lbs	☉
	7'	79.75"	W☒Ⓞ258F-84	17	46 lbs	☉
	8'	96.5"	W☒Ⓞ258F-96	21	55 lbs	☉

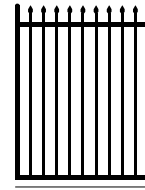

CLASSIC™

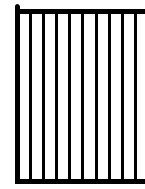

MAJESTIC™

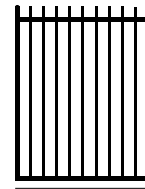

GENESIS™

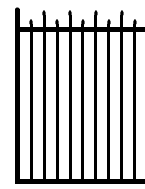

WARRIOR™

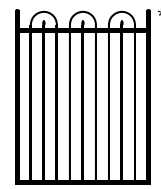

CRESCENT™

☒ = FENCE STYLES AVAILABLE | **C** = Classic **M** = Majestic **G** = Genesis **W** = Warrior **L** = Crescent*

Ⓞ = COLOR OPTIONS AVAILABLE | **B** = Black

☉ = NON-STOCKED PRODUCT | For details, see Ameristar's Sales Policy in the catalog guide.

*Not available in Crescent for 3.5' or 5' gate openings | †18 pickets per gate leaf in Crescent

Notes: Gate heights are nominal & gate widths are actual. Gate hardware sold separately. See Ornamental Gate Hardware section for more details.

Effective: 05/01/24

MONTAGE® | 2-RAIL DOUBLE SWING GATES

4" AIR GAP | FLUSH BOTTOM | GATE HARDWARE SOLD SEPARATELY

	OPENING	LEAF WIDTH	ITEM NUMBER	PICKET QTY	WEIGHT	STOCKING
3' HEIGHT	7'	36.5"	W☒⊗234F-84D*	7	38 lbs	☉
	8'	45"	W☒⊗234F-96D	9	44 lbs	☉
	10'	62.5"	W☒⊗234F-120D*	13	54 lbs	☉
	12'	71"	W☒⊗234F-144D	15	60 lbs	☉
	14'	79.75"	W☒⊗234F-168D	17†	68 lbs	☉
3.5' HEIGHT	16'	96.5"	W☒⊗234F-192D	21	72 lbs	☉
	7'	36.5"	W☒⊗240F-84D*	7	42 lbs	☉
	8'	45"	W☒⊗240F-96D	9	48 lbs	☉
	10'	62.5"	W☒⊗240F-120D*	13	62 lbs	☉
	12'	71"	W☒⊗240F-144D	15	68 lbs	☉
4' HEIGHT	14'	79.75"	W☒⊗240F-168D	17†	76 lbs	☉
	16'	96.5"	W☒⊗240F-192D	21	82 lbs	☉
	7'	36.5"	W☒⊗246F-84D*	7	50 lbs	☉
	8'	45"	W☒⊗246F-96D	9	54 lbs	<u>MB</u>
	10'	62.5"	W☒⊗246F-120D*	13	64 lbs	<u>MB</u>
5' HEIGHT	12'	71"	W☒⊗246F-144D	15	74 lbs	☉
	14'	79.75"	W☒⊗246F-168D	17†	84 lbs	☉
	16'	96.5"	W☒⊗246F-192D	21	92 lbs	☉
	7'	36.5"	W☒⊗258F-84D*	7	60 lbs	☉
	8'	45"	W☒⊗258F-96D	9	64 lbs	<u>MB</u>
5' HEIGHT	10'	62.5"	W☒⊗258F-120D*	13	76 lbs	☉
	12'	71"	W☒⊗258F-144D	15	88 lbs	☉
	14'	79.75"	W☒⊗258F-168D	17†	98 lbs	☉
	16'	96.5"	W☒⊗258F-192D	21	110 lbs	☉

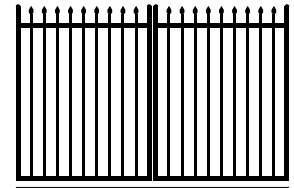

CLASSIC™

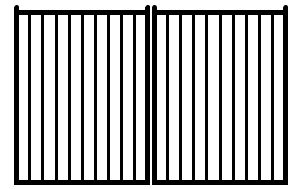

MAJESTIC™

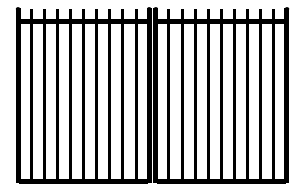

GENESIS™

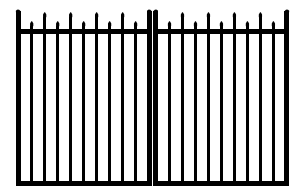

WARRIOR™

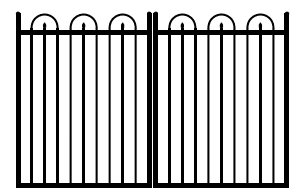

CRESCENT™

☒ = FENCE STYLES AVAILABLE | C = Classic M = Majestic G = Genesis W = Warrior L = Crescent*

⊗ = COLOR OPTIONS AVAILABLE | B = Black

☉ = NON-STOCKED PRODUCT | For details, see Ameristar's Sales Policy in the catalog guide.

*Not available in Crescent for 7' or 10' gate openings | †18 pickets per gate leaf in Crescent

Notes: Two gate leaves included for double all gates. Gate heights are nominal & gate widths are actual. Gate hardware sold separately. See Ornamental Gate Hardware section for more details.

Effective: 05/01/2024

MONTAGE® | 2-RAIL SINGLE SWING GATES

3" AIR GAP | FLUSH BOTTOM | GATE HARDWARE SOLD SEPARATELY

	OPENING	LEAF WIDTH	ITEM NUMBER	PICKET QTY	WEIGHT	STOCKING
3' HEIGHT	3.5'	36.5"	RM ⊗234F-42	9	17 lbs	⊙
	4'	45"	RM ⊗234F-48	11	21 lbs	⊙
	5'	62.5"	RM ⊗234F-60	16	27 lbs	⊙
	6'	71"	RM ⊗234F-72	19	32 lbs	⊙
	7'	79.75"	RM ⊗234F-84	21	39 lbs	⊙
	8'	96.5"	RM ⊗234F-96	26	42 lbs	⊙
3.5' HEIGHT	3.5'	36.5"	RM ⊗240F-42	9	21 lbs	⊙
	4'	45"	RM ⊗240F-48	11	24 lbs	⊙
	5'	62.5"	RM ⊗240F-60	16	31 lbs	⊙
	6'	71"	RM ⊗240F-72	19	36 lbs	⊙
	7'	79.75"	RM ⊗240F-84	21	41 lbs	⊙
	8'	96.5"	RM ⊗240F-96	26	45 lbs	⊙
4' HEIGHT	3.5'	36.5"	RM ⊗246F-42	9	26 lbs	⊙
	4'	45"	RM ⊗246F-48	11	29 lbs	⊙
	5'	62.5"	RM ⊗246F-60	16	35 lbs	⊙
	6'	71"	RM ⊗246F-72	19	41 lbs	⊙
	7'	79.75"	RM ⊗246F-84	21	44 lbs	⊙
	8'	96.5"	RM ⊗246F-96	26	52 lbs	⊙

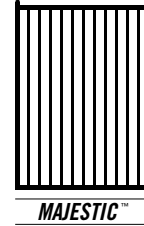

⊗ = COLOR OPTIONS AVAILABLE | B = Black

⊙ = NON-STOCKED PRODUCT | For details, see Ameristar's Sales Policy in the catalog guide.

Notes: Gate heights are nominal & gate widths are actual. Gate hardware sold separately. See Ornamental Gate Hardware section for more details.

Effective: 05/01/24

MONTAGE® | 2-RAIL DOUBLE SWING GATES

3" AIR GAP | FLUSH BOTTOM | GATE HARDWARE SOLD SEPARATELY

	OPENING	LEAF WIDTH	ITEM NUMBER	PICKET QTY	WEIGHT	STOCKING
3' HEIGHT	7'	36.5"	RMⓧ234F-84D	9	42 lbs	⓪
	8'	45"	RMⓧ234F-96D	11	46 lbs	⓪
	10'	62.5"	RMⓧ234F-120D	16	58 lbs	⓪
	12'	71"	RMⓧ234F-144D	19	68 lbs	⓪
	14'	79.75"	RMⓧ234F-168D	21	68 lbs	⓪
	16'	96.5"	RMⓧ234F-192D	26	80 lbs	⓪
3.5' HEIGHT	7'	36.5"	RMⓧ240F-84D	9	46 lbs	⓪
	8'	45"	RMⓧ240F-96D	11	52 lbs	⓪
	10'	62.5"	RMⓧ240F-120D	16	66 lbs	⓪
	12'	71"	RMⓧ240F-144D	19	76 lbs	⓪
	14'	79.75"	RMⓧ240F-168D	21	78 lbs	⓪
	16'	96.5"	RMⓧ240F-192D	26	90 lbs	⓪
4' HEIGHT	7'	36.5"	RMⓧ246F-84D	9	54 lbs	⓪
	8'	45"	RMⓧ246F-96D	11	60 lbs	⓪
	10'	62.5"	RMⓧ246F-120D	16	72 lbs	⓪
	12'	71"	RMⓧ246F-144D	19	84 lbs	⓪
	14'	79.75"	RMⓧ246F-168D	21	88 lbs	⓪
	16'	96.5"	RMⓧ246F-192D	26	104 lbs	⓪

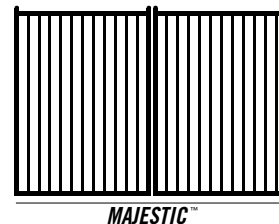

ⓧ = COLOR OPTIONS AVAILABLE | B = Black

⓪ = NON-STOCKED PRODUCT | For details, see Ameristar's Sales Policy in the catalog guide.

Notes: Two gate leaves included for double all gates. Gate heights are nominal & gate widths are actual. Gate hardware sold separately. See Ornamental Gate Hardware section for more details.

Effective: 05/01/2024

TO PLACE YOUR ORDER CALL 888-333-3422 | VISIT AMERISTARPERIMETER.COM |

AMERISTAR
ASSA ABLOY

MONTAGE® | 3-RAIL SINGLE SWING GATES

4" AIR GAP | STANDARD BOTTOM | GATE HARDWARE SOLD SEPARATELY

	OPENING	LEAF WIDTH	ITEM NUMBER	PICKET QTY	WEIGHT	STOCKING
3' HEIGHT	3.5'	36.5"	W☒⊗334-42*	7	19 lbs	☉
	4'	45"	W☒⊗334-48	9	22 lbs	☉
	5'	62.5"	W☒⊗334-60*	13	29 lbs	☉
	6'	71"	W☒⊗334-72	15	32 lbs	☉
	7'	79.75"	W☒⊗334-84	17†	36 lbs	☉
	8'	96.5"	W☒⊗334-96	21	42 lbs	☉
3.5' HEIGHT	3.5'	36.5"	W☒⊗340-42*	7	21 lbs	☉
	4'	45"	W☒⊗340-48	9	25 lbs	☉
	5'	62.5"	W☒⊗340-60*	13	32 lbs	☉
	6'	71"	W☒⊗340-72	15	36 lbs	☉
	7'	79.75"	W☒⊗340-84	17†	39 lbs	☉
	8'	96.5"	W☒⊗340-96	21	47 lbs	☉
4' HEIGHT	3.5'	36.5"	W☒⊗346-42*	7	26 lbs	MB
	4'	45"	W☒⊗346-48	9	28 lbs	CB MB GB
	5'	62.5"	W☒⊗346-60*	13	36 lbs	CB MB GB
	6'	71"	W☒⊗346-72	15	40 lbs	CB MB
	7'	79.75"	W☒⊗346-84	17†	44 lbs	☉
	8'	96.5"	W☒⊗346-96	21	52 lbs	☉
5' HEIGHT	3.5'	36.5"	W☒⊗358-42*	7	30 lbs	☉
	4'	45"	W☒⊗358-48	9	33 lbs	CB MB GB
	5'	62.5"	W☒⊗358-60*	13	42 lbs	CB MB GB
	6'	71"	W☒⊗358-72	15	47 lbs	CB
	7'	79.75"	W☒⊗358-84	17†	51 lbs	☉
	8'	96.5"	W☒⊗358-96	21	61 lbs	☉
6' HEIGHT	3.5'	36.5"	W☒⊗370-42*	7	35 lbs	☉
	4'	45"	W☒⊗370-48	9	38 lbs	CB MB GB
	5'	62.5"	W☒⊗370-60*	13	48 lbs	CB MB
	6'	71"	W☒⊗370-72	15	54 lbs	CB MB
	7'	79.75"	W☒⊗370-84	17†	59 lbs	☉
	8'	96.5"	W☒⊗370-96	21	70 lbs	☉

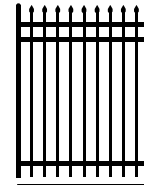

CLASSIC™

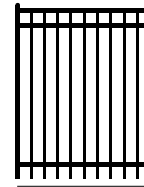

MAJESTIC™

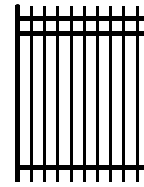

GENESIS™

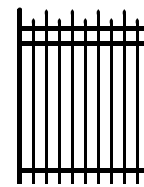

WARRIOR™

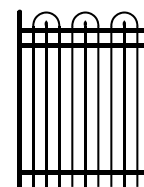

CRESCENT™

☒ = FENCE STYLES AVAILABLE | **C** = Classic **M** = Majestic **G** = Genesis **W** = Warrior **L** = Crescent*

⊗ = COLOR OPTIONS AVAILABLE | **B** = Black

☉ = NON-STOCKED PRODUCT | For details, see Ameristar's Sales Policy in the catalog guide.

*Not available in Crescent for 3.5' or 5' gate openings | † 18 pickets per gate leaf in Crescent

Notes: Gate heights are nominal & gate widths are actual. Gate hardware sold separately. See Ornamental Gate Hardware section for more details.

Effective: 05/01/24

MONTAGE® | 3-RAIL DOUBLE SWING GATES

4" AIR GAP | STANDARD BOTTOM | GATE HARDWARE SOLD SEPARATELY

	OPENING	LEAF WIDTH	ITEM NUMBER	PICKET QTY	WEIGHT	STOCKING
3' HEIGHT	7'	36.5"	W⊗ⓧ334-84D*	7	42 lbs	⊙
	8'	45"	W⊗ⓧ334-96D	9	48 lbs	⊙
	10'	62.5"	W⊗ⓧ334-120D*	13	62 lbs	⊙
	12'	71"	W⊗ⓧ334-144D	15	68 lbs	⊙
	14'	79.75"	W⊗ⓧ334-168D	17†	72 lbs	⊙
3.5' HEIGHT	16'	96.5"	W⊗ⓧ334-192D	21	84 lbs	⊙
	7'	36.5"	W⊗ⓧ340-84D*	7	46 lbs	⊙
	8'	45"	W⊗ⓧ340-96D	9	54 lbs	⊙
	10'	62.5"	W⊗ⓧ340-120D*	13	64 lbs	⊙
	12'	71"	W⊗ⓧ340-144D	15	76 lbs	⊙
4' HEIGHT	14'	79.75"	W⊗ⓧ340-168D	17†	80 lbs	⊙
	16'	96.5"	W⊗ⓧ340-192D	21	94 lbs	⊙
	7'	36.5"	W⊗ⓧ346-84D*	7	54 lbs	MB
	8'	45"	W⊗ⓧ346-96D	9	60 lbs	CB MB GB
	10'	62.5"	W⊗ⓧ346-120D*	13	68 lbs	CB MB GB
5' HEIGHT	12'	71"	W⊗ⓧ346-144D	15	84 lbs	CB MB
	14'	79.75"	W⊗ⓧ346-168D	17†	88 lbs	⊙
	16'	96.5"	W⊗ⓧ346-192D	21	104 lbs	⊙
	7'	36.5"	W⊗ⓧ358-84D*	7	64 lbs	⊙
	8'	45"	W⊗ⓧ358-96D	9	70 lbs	CB MB GB
6' HEIGHT	10'	62.5"	W⊗ⓧ358-120D*	13	80 lbs	CB MB GB
	12'	71"	W⊗ⓧ358-144D	15	98 lbs	CB
	14'	79.75"	W⊗ⓧ358-168D	17†	102 lbs	⊙
	16'	96.5"	W⊗ⓧ358-192D	21	122 lbs	⊙
	7'	36.5"	W⊗ⓧ370-84D*	7	74 lbs	⊙
CRESCENT*	8'	45"	W⊗ⓧ370-96D	9	80 lbs	CB MB GB
	10'	62.5"	W⊗ⓧ370-120D*	13	92 lbs	CB MB
	12'	71"	W⊗ⓧ370-144D	15	112 lbs	CB MB
	14'	79.75"	W⊗ⓧ370-168D	17†	118 lbs	⊙
	16'	96.5"	W⊗ⓧ370-192D	21	140 lbs	⊙

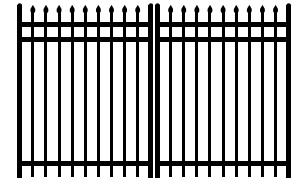

CLASSIC™

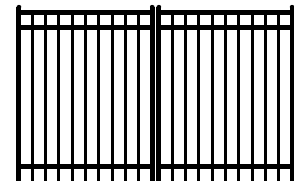

MAJESTIC™

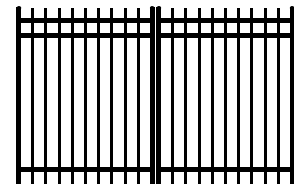

GENESIS™

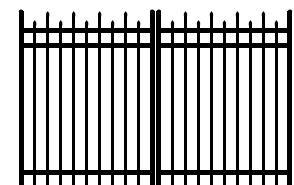

WARRIOR™

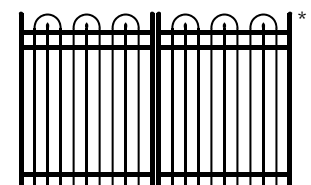

CRESCENT™

⊗ = FENCE STYLES AVAILABLE | **C** = Classic **M** = Majestic **G** = Genesis **W** = Warrior **L** = Crescent*

ⓧ = COLOR OPTIONS AVAILABLE | **B** = Black

⊙ = NON-STOCKED PRODUCT | For details, see Ameristar's Sales Policy in the catalog guide.

*Not available in Crescent for 7' or 10' gate openings | † 18 pickets per gate leaf in Crescent

Notes: Two gate leaves included for double all gates. Gate heights are nominal & gate widths are actual. Gate hardware sold separately. See Ornamental Gate Hardware section for more details.

Effective: 05/01/2024

TO PLACE YOUR ORDER CALL 888-333-3422 | VISIT AMERISTARPERIMETER.COM

AMERISTAR
ASSA ABLOY

MONTAGE® | 3-RAIL SINGLE SWING GATES

3" AIR GAP | STANDARD BOTTOM | GATE HARDWARE SOLD SEPARATELY

	OPENING	LEAF WIDTH	ITEM NUMBER	PICKET QTY	WEIGHT	STOCKING
3' HEIGHT	3.5'	36.5"	R☒ⓧ334-42	9	21 lbs	☉
	4'	45"	R☒ⓧ334-48	11	24 lbs	☉
	5'	62.5"	R☒ⓧ334-60	16	31 lbs	☉
	6'	71"	R☒ⓧ334-72	19	36 lbs	☉
	7'	79.75"	R☒ⓧ334-84	21	39 lbs	☉
3.5' HEIGHT	3.5'	36.5"	R☒ⓧ340-42	9	23 lbs	☉
	4'	45"	R☒ⓧ340-48	11	27 lbs	☉
	5'	62.5"	R☒ⓧ340-60	16	34 lbs	☉
	6'	71"	R☒ⓧ340-72	19	40 lbs	☉
	7'	79.75"	R☒ⓧ340-84	21	44 lbs	☉
4' HEIGHT	3.5'	36.5"	R☒ⓧ346-42	9	28 lbs	☉
	4'	45"	R☒ⓧ346-48	11	31 lbs	CB MB
	5'	62.5"	R☒ⓧ346-60	16	37 lbs	☉
	6'	71"	R☒ⓧ346-72	19	45 lbs	☉
	7'	79.75"	R☒ⓧ346-84	21	49 lbs	☉
5' HEIGHT	3.5'	36.5"	R☒ⓧ358-42	9	33 lbs	☉
	4'	45"	R☒ⓧ358-48	11	37 lbs	☉
	5'	62.5"	R☒ⓧ358-60	16	44 lbs	☉
	6'	71"	R☒ⓧ358-72	19	53 lbs	☉
	7'	79.75"	R☒ⓧ358-84	21	58 lbs	☉
6' HEIGHT	3.5'	36.5"	R☒ⓧ370-42	9	38 lbs	☉
	4'	45"	R☒ⓧ370-48	11	43 lbs	☉
	5'	62.5"	R☒ⓧ370-60	16	51 lbs	☉
	6'	71"	R☒ⓧ370-72	19	61 lbs	☉
	7'	79.75"	R☒ⓧ370-84	21	67 lbs	☉
	8'	96.5"	R☒ⓧ370-96	26	79 lbs	☉

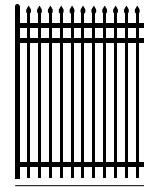

CLASSIC™

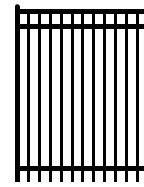

MAJESTIC™

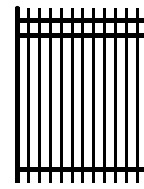

GENESIS™

☒ = FENCE STYLES AVAILABLE | C = Classic M = Majestic G = Genesis

ⓧ = COLOR OPTIONS AVAILABLE | B = Black

☉ = NON-STOCKED PRODUCT | For details, see Ameristar's Sales Policy in the catalog guide.

Notes: Gate heights are nominal & gate widths are actual. Gate hardware sold separately. See Ornamental Gate Hardware section for more details.

Effective: 05/01/24

MONTAGE® | 3-RAIL DOUBLE SWING GATES

3" AIR GAP | STANDARD BOTTOM | GATE HARDWARE SOLD SEPARATELY

	OPENING	LEAF WIDTH	ITEM NUMBER	PICKET QTY	WEIGHT	STOCKING
3' HEIGHT	7'	36.5"	R☒⊗334-84D	9	46 lbs	⊙
	8'	45"	R☒⊗334-96D	11	52 lbs	⊙
	10'	62.5"	R☒⊗334-120D	16	66 lbs	⊙
	12'	71"	R☒⊗334-144D	19	76 lbs	⊙
	14'	79.75"	R☒⊗334-168D	21	80 lbs	⊙
	16'	96.5"	R☒⊗334-192D	26	92 lbs	⊙
3.5' HEIGHT	7'	36.5"	R☒⊗340-84D	9	50 lbs	⊙
	8'	45"	R☒⊗340-96D	11	58 lbs	⊙
	10'	62.5"	R☒⊗340-120D	16	72 lbs	⊙
	12'	71"	R☒⊗340-144D	19	84 lbs	⊙
	14'	79.75"	R☒⊗340-168D	21	88 lbs	⊙
	16'	96.5"	R☒⊗340-192D	26	102 lbs	⊙
4' HEIGHT	7'	36.5"	R☒⊗346-84D	9	60 lbs	⊙
	8'	45"	R☒⊗346-96D	11	66 lbs	CB MB
	10'	62.5"	R☒⊗346-120D	16	78 lbs	⊙
	12'	71"	R☒⊗346-144D	19	94 lbs	⊙
	14'	79.75"	R☒⊗346-168D	21	98 lbs	⊙
	16'	96.5"	R☒⊗346-192D	26	116 lbs	⊙
5' HEIGHT	7'	36.5"	R☒⊗358-84D	9	70 lbs	⊙
	8'	45"	R☒⊗358-96D	11	78 lbs	⊙
	10'	62.5"	R☒⊗358-120D	16	92 lbs	⊙
	12'	71"	R☒⊗358-144D	19	110 lbs	⊙
	14'	79.75"	R☒⊗358-168D	21	116 lbs	⊙
	16'	96.5"	R☒⊗358-192D	26	138 lbs	⊙
6' HEIGHT	7'	36.5"	R☒⊗370-84D	9	80 lbs	⊙
	8'	45"	R☒⊗370-96D	11	90 lbs	⊙
	10'	62.5"	R☒⊗370-120D	16	106 lbs	⊙
	12'	71"	R☒⊗370-144D	19	128 lbs	⊙
	14'	79.75"	R☒⊗370-168D	21	134 lbs	⊙
	16'	96.5"	R☒⊗370-192D	26	158 lbs	⊙

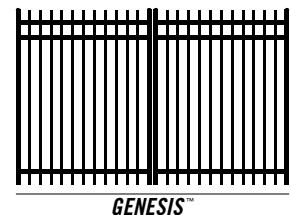
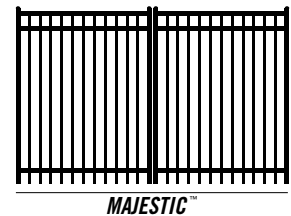
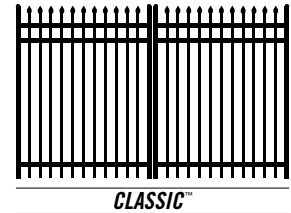

☒ = FENCE STYLES AVAILABLE | C = Classic M = Majestic G = Genesis

⊗ = COLOR OPTIONS AVAILABLE | B = Black

⊙ = NON-STOCKED PRODUCT | For details, see Ameristar's Sales Policy in the catalog guide.

Notes: Two gate leaves included for double all gates. Gate heights are nominal & gate widths are actual. Gate hardware sold separately. See Ornamental Gate Hardware section for more details.

Effective: 05/01/2024

TO PLACE YOUR ORDER CALL 888-333-3422 | VISIT AMERISTARPERIMETER.COM

AMERISTAR
ASSA ABLOY

MONTAGE® | 3-RAIL SINGLE SWING GATES

4" AIR GAP | FLUSH BOTTOM | GATE HARDWARE SOLD SEPARATELY

	OPENING	LEAF WIDTH	ITEM NUMBER	PICKET QTY	WEIGHT	STOCKING
3' HEIGHT	3.5'	36.5"	W☒☉334F-42*	7	20 lbs	☉
	4'	45"	W☒☉334F-48	9	22 lbs	☉
	5'	62.5"	W☒☉334F-60*	13	29 lbs	☉
	6'	71"	W☒☉334F-72	15	32 lbs	☉
	7'	79.75"	W☒☉334F-84	17†	36 lbs	☉
	8'	96.5"	W☒☉334F-96	21	42 lbs	☉
3.5' HEIGHT	3.5'	36.5"	W☒☉340F-42*	7	22 lbs	☉
	4'	45"	W☒☉340F-48	9	25 lbs	☉
	5'	62.5"	W☒☉340F-60*	13	32 lbs	☉
	6'	71"	W☒☉340F-72	15	36 lbs	☉
	7'	79.75"	W☒☉340F-84	17†	39 lbs	☉
	8'	96.5"	W☒☉340F-96	21	47 lbs	☉
4' HEIGHT	3.5'	36.5"	W☒☉346F-42*	7	25 lbs	☉
	4'	45"	W☒☉346F-48	9	28 lbs	MB
	5'	62.5"	W☒☉346F-60*	13	36 lbs	☉
	6'	71"	W☒☉346F-72	15	40 lbs	☉
	7'	79.75"	W☒☉346F-84	17†	44 lbs	☉
	8'	96.5"	W☒☉346F-96	21	52 lbs	☉
4.5' HEIGHT	3.5'	36.5"	WM☉354F-42*	7	29 lbs	☉
	4'	45"	WM☉354F-48	9	32 lbs	☉
	5'	62.5"	WM☉354F-60*	13	40 lbs	☉
	6'	71"	WM☉354F-72	15	45 lbs	☉
	7'	79.75"	WM☉354F-84	17	48 lbs	☉
	8'	96.5"	WM☉354F-96	21	57 lbs	☉

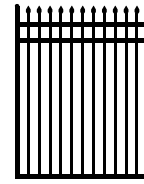

CLASSIC™

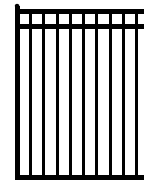

MAJESTIC™

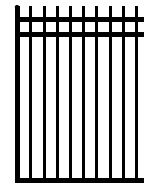

GENESIS™

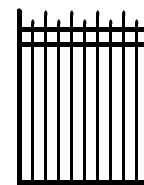

WARRIOR™

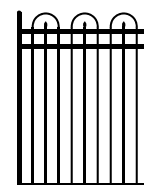

CRESCENT™

5' & 6' HEIGHTS CONTINUED ON NEXT PAGE

☒ = FENCE STYLES AVAILABLE | ☉ = Classic | M = Majestic | G = Genesis | W = Warrior | L = Crescent*

☉ = COLOR OPTIONS AVAILABLE | B = Black

☉ = NON-STOCKED PRODUCT | For details, see Ameristar's Sales Policy in the catalog guide.

*Not available in Crescent for 3.5' or 5' gate openings | †18 pickets per gate leaf in Crescent

Notes: Gate heights are nominal & gate widths are actual. Gate hardware sold separately. See Ornamental Gate Hardware section for more details.

Effective: 05/01/24

MONTAGE® | 3-RAIL SINGLE SWING GATES

4" AIR GAP | FLUSH BOTTOM | GATE HARDWARE SOLD SEPARATELY

	OPENING	LEAF WIDTH	ITEM NUMBER	PICKET QTY	WEIGHT	STOCKING
5' HEIGHT	3.5'	36.5"	W☒Ⓞ358F-42*	7	30 lbs	☉
	4'	45"	W☒Ⓞ358F-48	9	33 lbs	CB MB
	5'	62.5"	W☒Ⓞ358F-60*	13	42 lbs	MB
	6'	71"	W☒Ⓞ358F-72	15	47 lbs	☉
	7'	79.75"	W☒Ⓞ358F-84	17†	51 lbs	☉
6' HEIGHT	8'	96.5"	W☒Ⓞ358F-96	21	61 lbs	☉
	3.5'	36.5"	W☒Ⓞ370F-42*	7	35 lbs	☉
	4'	45"	W☒Ⓞ370F-48	9	38 lbs	MB
	5'	62.5"	W☒Ⓞ370F-60*	13	48 lbs	☉
	6'	71"	W☒Ⓞ370F-72	15	54 lbs	☉
	7'	79.75"	W☒Ⓞ370F-84	17†	59 lbs	☉
	8'	96.5"	W☒Ⓞ370F-96	21	70 lbs	☉

☒ = FENCE STYLES AVAILABLE | **C** = Classic | **M** = Majestic | **G** = Genesis | **W** = Warrior | **L** = Crescent*

Ⓞ = COLOR OPTIONS AVAILABLE | **B** = Black

☉ = NON-STOCKED PRODUCT | For details, see Ameristar's Sales Policy in the catalog guide.

*Not available in Crescent for 3.5' or 5' gate openings | †18 pickets per gate leaf in Crescent

Notes: Gate heights are nominal & gate widths are actual. Gate hardware sold separately. See Ornamental Gate Hardware section for more details.

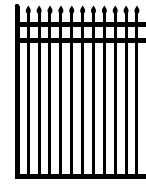

CLASSIC™

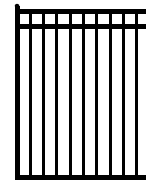

MAJESTIC™

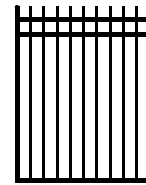

GENESIS™

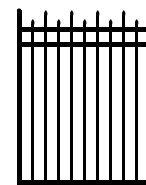

WARRIOR™

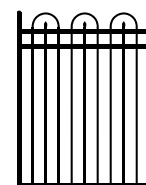

CRESCENT™

Effective: 05/01/2024

MONTAGE® | 3-RAIL DOUBLE SWING GATES

4" AIR GAP | FLUSH BOTTOM | GATE HARDWARE SOLD SEPARATELY

	OPENING	LEAF WIDTH	ITEM NUMBER	PICKET QTY	WEIGHT	STOCKING
3' HEIGHT	7'	36.5"	W☒Ⓞ334F-84D*	7	42 lbs	☉
	8'	45"	W☒Ⓞ334F-96D	9	48 lbs	☉
	10'	62.5"	W☒Ⓞ334F-120D*	13	62 lbs	☉
	12'	71"	W☒Ⓞ334F-144D	15	68 lbs	☉
	14'	79.75"	W☒Ⓞ334F-168D	17†	72 lbs	☉
	16'	96.5"	W☒Ⓞ334F-192D	21	84 lbs	☉
3.5' HEIGHT	7'	36.5"	W☒Ⓞ340F-84D*	7	46 lbs	☉
	8'	45"	W☒Ⓞ340F-96D	9	54 lbs	☉
	10'	62.5"	W☒Ⓞ340F-120D*	13	64 lbs	☉
	12'	71"	W☒Ⓞ340F-144D	15	76 lbs	☉
	14'	79.75"	W☒Ⓞ340F-168D	17†	78 lbs	☉
	16'	96.5"	W☒Ⓞ340F-192D	21	94 lbs	☉
4' HEIGHT	7'	36.5"	W☒Ⓞ346F-84D*	7	54 lbs	☉
	8'	45"	W☒Ⓞ346F-96D	9	60 lbs	MB
	10'	62.5"	W☒Ⓞ346F-120D*	13	68 lbs	☉
	12'	71"	W☒Ⓞ346F-144D	15	84 lbs	☉
	14'	79.75"	W☒Ⓞ346F-168D	17†	88 lbs	☉
	16'	96.5"	W☒Ⓞ346F-192D	21	104 lbs	☉
4.5' HEIGHT	7'	36.5"	WM☒Ⓞ354F-84D*	7	60 lbs	☉
	8'	45"	WM☒Ⓞ354F-96D	9	66 lbs	☉
	10'	62.5"	WM☒Ⓞ354F-120D*	13	74 lbs	☉
	12'	71"	WM☒Ⓞ354F-144D	15	92 lbs	☉
	14'	79.75"	WM☒Ⓞ354F-168D	17†	96 lbs	☉
	16'	96.5"	WM☒Ⓞ354F-192D	21	114 lbs	☉

5' & 6' HEIGHTS CONTINUED ON NEXT PAGE

☒ = FENCE STYLES AVAILABLE | C = Classic | M = Majestic | G = Genesis | W = Warrior | L = Crescent*

Ⓞ = COLOR OPTIONS AVAILABLE | B = Black

☉ = NON-STOCKED PRODUCT | For details, see Ameristar's Sales Policy in the catalog guide.

*Not available in Crescent for 7' or 10' gate openings | † 18 pickets per gate leaf in Crescent

Notes: Two gate leaves included for double all gates. Gate heights are nominal & gate widths are actual. Gate hardware sold separately. See Ornamental Gate Hardware section for more details.

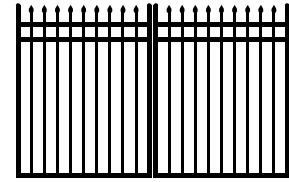

CLASSIC™

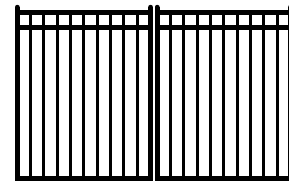

MAJESTIC™

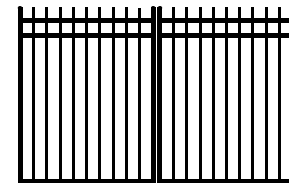

GENESIS™

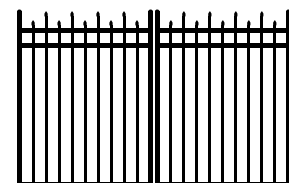

WARRIOR™

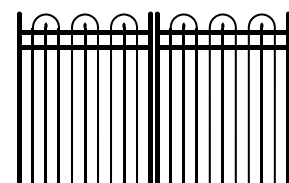

CRESCENT™

MONTAGE® | 3-RAIL DOUBLE SWING GATES

4" AIR GAP | FLUSH BOTTOM | GATE HARDWARE SOLD SEPARATELY

	OPENING	LEAF WIDTH	ITEM NUMBER	PICKET QTY	WEIGHT	STOCKING
5' HEIGHT	7'	36.5"	W☒Ⓞ358F-84D*	7	64 lbs	☉
	8'	45"	W☒Ⓞ358F-96D	9	70 lbs	CB MB
	10'	62.5"	W☒Ⓞ358F-120D*	13	80 lbs	MB
	12'	71"	W☒Ⓞ358F-144D	15	98 lbs	☉
	14'	79.75"	W☒Ⓞ358F-168D	17†	102 lbs	☉
	16'	96.5"	W☒Ⓞ358F-192D	21	122 lbs	☉
6' HEIGHT	7'	36.5"	W☒Ⓞ370F-84D*	7	74 lbs	☉
	8'	45"	W☒Ⓞ370F-96D	9	80 lbs	MB
	10'	62.5"	W☒Ⓞ370F-120D*	13	92 lbs	☉
	12'	71"	W☒Ⓞ370F-144D	15	112 lbs	☉
	14'	79.75"	W☒Ⓞ370F-168D	17†	118 lbs	☉
	16'	96.5"	W☒Ⓞ370F-192D	21	140 lbs	☉

☒ = FENCE STYLES AVAILABLE | **C** = Classic | **M** = Majestic | **G** = Genesis | **W** = Warrior | **L** = Crescent*

Ⓞ = COLOR OPTIONS AVAILABLE | **B** = Black

☉ = NON-STOCKED PRODUCT | For details, see Ameristar's Sales Policy in the catalog guide.

*Not available in Crescent for 7' or 10' gate openings | †18 pickets per gate leaf in Crescent

Notes: Two gate leaves included for double all gates. Gate heights are nominal & gate widths are actual. Gate hardware sold separately. See Ornamental Gate Hardware section for more details.

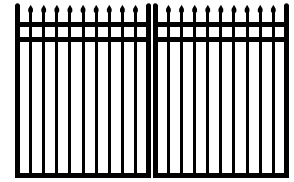

CLASSIC™

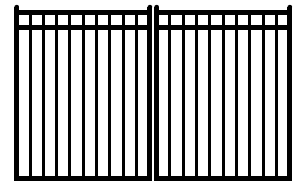

MAJESTIC™

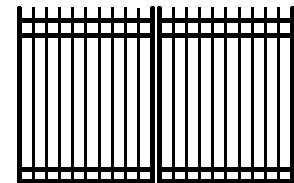

GENESIS™

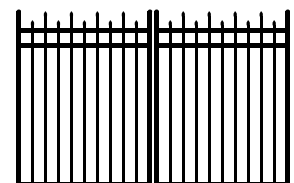

WARRIOR™

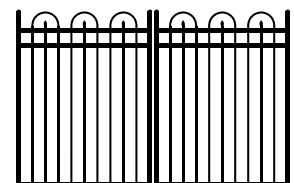

CRESCENT™*

Effective: 05/01/2024

MONTAGE® | 3-RAIL SINGLE SWING GATES

3" AIR GAP | FLUSH BOTTOM | GATE HARDWARE SOLD SEPARATELY

	OPENING	LEAF WIDTH	ITEM NUMBER	PICKET QTY	WEIGHT	STOCKING
3' HEIGHT	3.5'	36.5"	R☒Ⓞ334F-42	9	21 lbs	☉
	4'	45"	R☒Ⓞ334F-48	11	24 lbs	☉
	5'	62.5"	R☒Ⓞ334F-60	16	31 lbs	☉
	6'	71"	R☒Ⓞ334F-72	19	36 lbs	☉
	7'	79.75"	R☒Ⓞ334F-84	21	39 lbs	☉
	8'	96.5"	R☒Ⓞ334F-96	26	46 lbs	☉
3.5' HEIGHT	3.5'	36.5"	R☒Ⓞ340F-42	9	23 lbs	☉
	4'	45"	R☒Ⓞ340F-48	11	27 lbs	☉
	5'	62.5"	R☒Ⓞ340F-60	16	34 lbs	☉
	6'	71"	R☒Ⓞ340F-72	19	40 lbs	☉
	7'	79.75"	R☒Ⓞ340F-84	21	44 lbs	☉
	8'	96.5"	R☒Ⓞ340F-96	26	51 lbs	☉
4' HEIGHT	3.5'	36.5"	R☒Ⓞ346F-42	9	28 lbs	☉
	4'	45"	R☒Ⓞ346F-48	11	31 lbs	☉
	5'	62.5"	R☒Ⓞ346F-60	16	37 lbs	☉
	6'	71"	R☒Ⓞ346F-72	19	45 lbs	☉
	7'	79.75"	R☒Ⓞ346F-84	21	49 lbs	☉
	8'	96.5"	R☒Ⓞ346F-96	26	58 lbs	☉
4.5' HEIGHT	3.5'	36.5"	RMⓄ354F-42	9	32 lbs	☉
	4'	45"	RMⓄ354F-48	11	35 lbs	☉
	5'	62.5"	RMⓄ354F-60	16	42 lbs	☉
	6'	71"	RMⓄ354F-72	19	52 lbs	☉
	7'	79.75"	RMⓄ354F-84	21	54 lbs	☉
	8'	96.5"	RMⓄ354F-96	26	64 lbs	☉

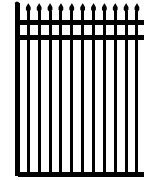

CLASSIC™

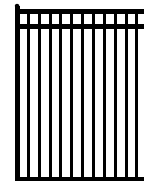

MAJESTIC™

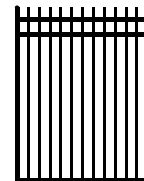

GENESIS™

5' & 6' HEIGHTS CONTINUED ON NEXT PAGE

☒ = FENCE STYLES AVAILABLE | C = Classic M = Majestic G = Genesis

Ⓞ = COLOR OPTIONS AVAILABLE | B = Black

☉ = NON-STOCKED PRODUCT | For details, see Ameristar's Sales Policy in the catalog guide.

Notes: Gate heights are nominal & gate widths are actual. Gate hardware sold separately. See Ornamental Gate Hardware section for more details.

Effective: 05/01/24

MONTAGE® | 3-RAIL SINGLE SWING GATES

3" AIR GAP | FLUSH BOTTOM | GATE HARDWARE SOLD SEPARATELY

	OPENING	LEAF WIDTH	ITEM NUMBER	PICKET QTY	WEIGHT	STOCKING
5' HEIGHT	3.5'	36.5"	R☒☒358F-42	9	33 lbs	☉
	4'	45"	R☒☒358F-48	11	37 lbs	☉
	5'	62.5"	R☒☒358F-60	16	44 lbs	☉
	6'	71"	R☒☒358F-72	19	53 lbs	☉
	7'	79.75"	R☒☒358F-84	21	58 lbs	☉
6' HEIGHT	8'	96.5"	R☒☒358F-96	26	69 lbs	☉
	3.5'	36.5"	R☒☒370F-42	9	38 lbs	☉
	4'	45"	R☒☒370F-48	11	43 lbs	☉
	5'	62.5"	R☒☒370F-60	16	51 lbs	☉
	6'	71"	R☒☒370F-72	19	61 lbs	☉
	7'	79.75"	R☒☒370F-84	21	67 lbs	☉
	8'	96.5"	R☒☒370F-96	26	79 lbs	☉

☒ = FENCE STYLES AVAILABLE | **C** = Classic | **M** = Majestic | **G** = Genesis

☒ = COLOR OPTIONS AVAILABLE | **B** = Black

☉ = NON-STOCKED PRODUCT | For details, see Ameristar's Sales Policy in the catalog guide.

Notes: Gate heights are nominal & gate widths are actual. Gate hardware sold separately. See Ornamental Gate Hardware section for more details.

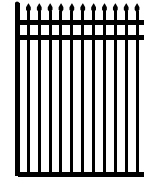

CLASSIC™

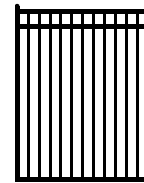

MAJESTIC™

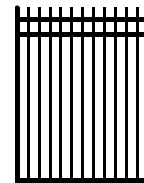

GENESIS™

Effective: 05/01/2024

TO PLACE YOUR ORDER CALL 888-333-3422 | VISIT AMERISTARPERIMETER.COM |

AMERISTAR
ASSA ABLOY

MONTAGE® | 3-RAIL DOUBLE SWING GATES

3" AIR GAP | FLUSH BOTTOM | GATE HARDWARE SOLD SEPARATELY

	OPENING	LEAF WIDTH	ITEM NUMBER	PICKET QTY	WEIGHT	STOCKING
3' HEIGHT	7'	36.5"	R☒⊗334F-84D	9	46 lbs	☉
	8'	45"	R☒⊗334F-96D	11	52 lbs	☉
	10'	62.5"	R☒⊗334F-120D	16	66 lbs	☉
	12'	71"	R☒⊗334F-144D	19	76 lbs	☉
	14'	79.75"	R☒⊗334F-168D	21	80 lbs	☉
3.5' HEIGHT	16'	96.5"	R☒⊗334F-192D	26	92 lbs	☉
	7'	36.5"	R☒⊗340F-84D	9	50 lbs	☉
	8'	45"	R☒⊗340F-96D	11	58 lbs	☉
	10'	62.5"	R☒⊗340F-120D	16	72 lbs	☉
	12'	71"	R☒⊗340F-144D	19	84 lbs	☉
4' HEIGHT	14'	79.75"	R☒⊗340F-168D	21	88 lbs	☉
	16'	96.5"	R☒⊗340F-192D	26	102 lbs	☉
	7'	36.5"	R☒⊗346F-84D	9	60 lbs	☉
	8'	45"	R☒⊗346F-96D	11	66 lbs	☉
	10'	62.5"	R☒⊗346F-120D	16	78 lbs	☉
4.5' HEIGHT	12'	71"	R☒⊗346F-144D	19	94 lbs	☉
	14'	79.75"	R☒⊗346F-168D	21	98 lbs	☉
	16'	96.5"	R☒⊗346F-192D	26	116 lbs	☉
	7'	36.5"	RM⊗354F-84D	9	66 lbs	☉
	8'	45"	RM⊗354F-96D	11	72 lbs	☉
5' HEIGHT	10'	62.5"	RM⊗354F-120D	16	86 lbs	☉
	12'	71"	RM⊗354F-144D	19	106 lbs	☉
	14'	79.75"	RM⊗354F-168D	21	110 lbs	☉
	16'	96.5"	RM⊗354F-192D	26	128 lbs	☉

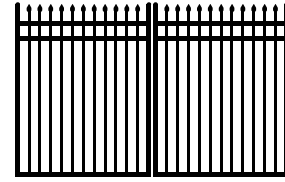

CLASSIC™

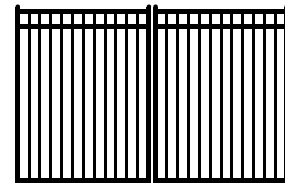

MAJESTIC™

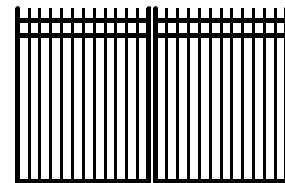

GENESIS™

5' & 6' HEIGHTS CONTINUED ON NEXT PAGE

☒ = FENCE STYLES AVAILABLE | C = Classic M = Majestic G = Genesis

⊗ = COLOR OPTIONS AVAILABLE | B = Black

☉ = NON-STOCKED PRODUCT | For details, see Ameristar's Sales Policy in the catalog guide.

Notes: Two gate leaves included for double all gates. Gate heights are nominal & gate widths are actual. Gate hardware sold separately. See Ornamental Gate Hardware section for more details.

Effective: 05/01/24

MONTAGE® | 3-RAIL DOUBLE SWING GATES

3" AIR GAP | FLUSH BOTTOM | GATE HARDWARE SOLD SEPARATELY

	OPENING	LEAF WIDTH	ITEM NUMBER	PICKET QTY	WEIGHT	STOCKING
5' HEIGHT	7'	36.5"	R☒ⓧ358F-84D	9	70 lbs	⊙
	8'	45"	R☒ⓧ358F-96D	11	78 lbs	⊙
	10'	62.5"	R☒ⓧ358F-120D	16	92 lbs	⊙
	12'	71"	R☒ⓧ358F-144D	19	110 lbs	⊙
	14'	79.75"	R☒ⓧ358F-168D	21	116 lbs	⊙
	16'	96.5"	R☒ⓧ358F-192D	26	138 lbs	⊙
6' HEIGHT	7'	36.5"	R☒ⓧ370F-84D	9	80 lbs	⊙
	8'	45"	R☒ⓧ370F-96D	11	90 lbs	⊙
	10'	62.5"	R☒ⓧ370F-120D	16	106 lbs	⊙
	12'	71"	R☒ⓧ370F-144D	19	128 lbs	⊙
	14'	79.75"	R☒ⓧ370F-168D	21	134 lbs	⊙
	16'	96.5"	R☒ⓧ370F-192D	26	158 lbs	⊙

☒ = FENCE STYLES AVAILABLE | C = Classic M = Majestic G = Genesis W = Warrior

ⓧ = COLOR OPTIONS AVAILABLE | B = Black

⊙ = NON-STOCKED PRODUCT | For details, see Ameristar's Sales Policy in the catalog guide.

Notes: Two gate leaves included for double all gates. Gate heights are nominal & gate widths are actual. Gate hardware sold separately. See Ornamental Gate Hardware section for more details.

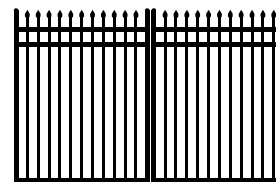

CLASSIC™

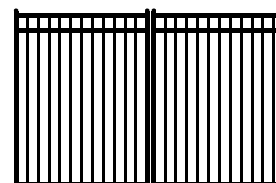

MAJESTIC™

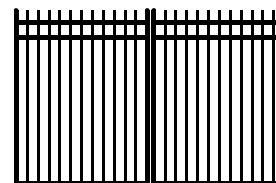

GENESIS™

Effective: 05/01/2024

Effective: 05/01/24

MONTAGE® | SINGLE SWING ARCHED GATE SPECIFICATIONS

1.25"sq x 16ga GATE ENDS | .9375"w x 1.25"h x 14ga RAILS | .590"sq x 18ga PICKETS

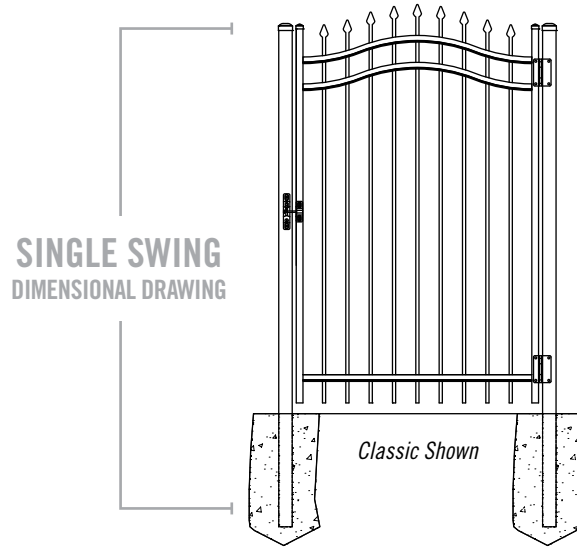

SINGLE SWING
ARCHED
HARDWARE KITS &
POST INTERSPACES

OPENING	LEAF WIDTH*	D&D GATE HARDWARE KIT			D&D POOL GATE HARDWARE KIT			SGBS2 BOLT ON HINGE KIT		
		HC	LC	P _s	HC	LC	P _s	HC	LC	P _s
3.5'	36.5"	1.125"	.75"	38.375"	1.125"	.75"	38.375"	2"	2"	40.5"
4'	45"	1.125"	.75"	46.875"	1.125"	.75"	46.875"	2"	2"	49"
5'	62.5"	1.125"	.75"	64.375"	1.125"	.75"	64.375"	2"	2"	66.5"
6'	71"	1.125"	.75"	72.875"	1.125"	.75"	72.875"	2"	2"	75"

W = width* | HC = hinge clearance | LC = latch clearance | P_s = gate post spacing**
* From outside to outside | ** From inside to inside

NOTE: GATE HARDWARE SOLD SEPARATELY. SEE ORNAMENTAL GATE HARDWARE SECTION FOR MORE DETAILS.

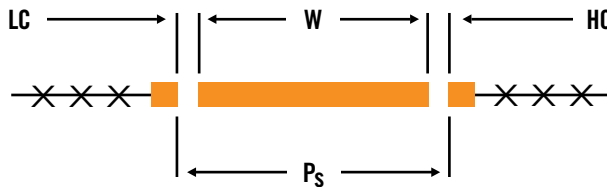

Effective: 05/01/2024

MONTAGE® | 2-RAIL SINGLE ARCHED SWING GATES

4" AIR GAP | STANDARD BOTTOM | GATE HARDWARE SOLD SEPARATELY

	OPENING	LEAF WIDTH	ITEM NUMBER	PICKET QTY	WEIGHT	STOCKING
3' HEIGHT	3.5'	36.5"	W☒⊗234-42A	7	18 lbs	⊙
	4'	45"	W☒⊗234-48A	9	22 lbs	⊙
	5'	62.5"	W☒⊗234-60A	13	27 lbs	⊙
	6'	71"	W☒⊗234-72A	15	31 lbs	⊙
3.5' HEIGHT	3.5'	36.5"	W☒⊗240-42A	7	20 lbs	⊙
	4'	45"	W☒⊗240-48A	9	24 lbs	⊙
	5'	62.5"	W☒⊗240-60A	13	31 lbs	⊙
	6'	71"	W☒⊗240-72A	15	36 lbs	⊙
4' HEIGHT	3.5'	36.5"	W☒⊗246-42A	7	24 lbs	⊙
	4'	45"	W☒⊗246-48A	9	27 lbs	⊙
	5'	62.5"	W☒⊗246-60A	13	34 lbs	⊙
	6'	71"	W☒⊗246-72A	15	37 lbs	⊙
5' HEIGHT	3.5'	36.5"	W☒⊗258-42A	7	26 lbs	⊙
	4'	45"	W☒⊗258-48A	9	32 lbs	⊙
	5'	62.5"	W☒⊗258-60A	13	38 lbs	⊙
	6'	71"	W☒⊗258-72A	15	44 lbs	⊙

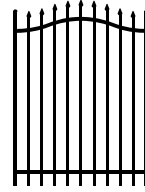

CLASSIC™

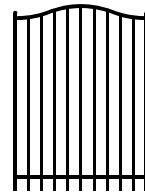

MAJESTIC™

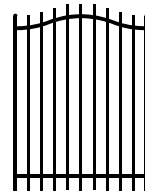

GENESIS™

☒ = FENCE STYLES AVAILABLE | **C** = Classic **M** = Majestic **G** = Genesis

⊗ = COLOR OPTIONS AVAILABLE | **B** = Black

⊙ = NON-STOCKED PRODUCT | For details, see Ameristar's Sales Policy in the catalog guide.

Notes: Gate heights are nominal & gate widths are actual. Gate hardware sold separately. See Ornamental Gate Hardware section for more details.

Effective: 05/01/24

MONTAGE® | 2-RAIL SINGLE ARCHED SWING GATES

4" AIR GAP | FLUSH BOTTOM | GATE HARDWARE SOLD SEPARATELY

	OPENING	LEAF WIDTH	ITEM NUMBER	PICKET QTY	WEIGHT	STOCKING
3' HEIGHT	3.5'	36.5"	W☒ⓧ234F-42A	7	18 lbs	☉
	4'	45"	W☒ⓧ234F-48A	9	23 lbs	☉
	5'	62.5"	W☒ⓧ234F-60A	13	27 lbs	☉
	6'	71"	W☒ⓧ234F-72A	15	31 lbs	☉
3.5' HEIGHT	3.5'	36.5"	W☒ⓧ240F-42A	7	20 lbs	☉
	4'	45"	W☒ⓧ240F-48A	9	24 lbs	☉
	5'	62.5"	W☒ⓧ240F-60A	13	31 lbs	☉
	6'	71"	W☒ⓧ240F-72A	15	36 lbs	☉
4' HEIGHT	3.5'	36.5"	W☒ⓧ246F-42A	7	24 lbs	☉
	4'	45"	W☒ⓧ246F-48A	9	27 lbs	☉
	5'	62.5"	W☒ⓧ246F-60A	13	34 lbs	☉
	6'	71"	W☒ⓧ246F-72A	15	37 lbs	☉
5' HEIGHT	3.5'	36.5"	W☒ⓧ258F-42A	7	26 lbs	☉
	4'	45"	W☒ⓧ258F-48A	9	32 lbs	☉
	5'	62.5"	W☒ⓧ258F-60A	13	38 lbs	☉
	6'	71"	W☒ⓧ258F-72A	15	44 lbs	☉

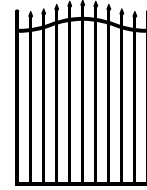

CLASSIC™

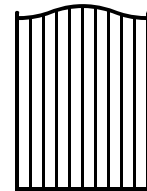

MAJESTIC™

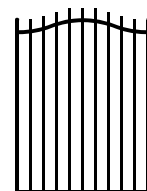

GENESIS™

☒ = FENCE STYLES AVAILABLE | **C** = Classic **M** = Majestic **G** = Genesisⓧ = COLOR OPTIONS AVAILABLE | **B** = Black

☉ = NON-STOCKED PRODUCT | For details, see Ameristar's Sales Policy in the catalog guide.

Notes: Gate heights are nominal & gate widths are actual. Gate hardware sold separately. See Ornamental Gate Hardware section for more details.

Effective: 05/01/2024

TO PLACE YOUR ORDER CALL 888-333-3422 | VISIT AMERISTARPERIMETER.COM |

AMERISTAR
ASSA ABLOY

MONTAGE® | 3-RAIL SINGLE ARCHED SWING GATES

4" AIR GAP | STANDARD BOTTOM | GATE HARDWARE SOLD SEPARATELY

	OPENING	LEAF WIDTH	ITEM NUMBER	PICKET QTY	WEIGHT	STOCKING
3' HEIGHT	3.5'	36.5"	W☒ⓧ334-42A	7	20 lbs	⊙
	4'	45"	W☒ⓧ334-48A	9	24 lbs	⊙
	5'	62.5"	W☒ⓧ334-60A	13	31 lbs	⊙
	6'	71"	W☒ⓧ334-72A	15	35 lbs	⊙
3.5' HEIGHT	3.5'	36.5"	W☒ⓧ340-42A	7	22 lbs	⊙
	4'	45"	W☒ⓧ340-48A	9	27 lbs	⊙
	5'	62.5"	W☒ⓧ340-60A	13	34 lbs	⊙
	6'	71"	W☒ⓧ340-72A	15	39 lbs	⊙
4' HEIGHT	3.5'	36.5"	W☒ⓧ346-42A	7	26 lbs	⊙
	4'	45"	W☒ⓧ346-48A	9	30 lbs	⊙
	5'	62.5"	W☒ⓧ346-60A	13	38 lbs	⊙
	6'	71"	W☒ⓧ346-72A	15	43 lbs	⊙
5' HEIGHT	3.5'	36.5"	W☒ⓧ358-42A	7	31 lbs	⊙
	4'	45"	W☒ⓧ358-48A	9	35 lbs	⊙
	5'	62.5"	W☒ⓧ358-60A	13	44 lbs	⊙
	6'	71"	W☒ⓧ358-72A	15	50 lbs	⊙
6' HEIGHT	3.5'	36.5"	W☒ⓧ370-42A	7	36 lbs	⊙
	4'	45"	W☒ⓧ370-48A	9	40 lbs	⊙
	5'	62.5"	W☒ⓧ370-60A	13	50 lbs	⊙
	6'	71"	W☒ⓧ370-72A	15	57 lbs	⊙

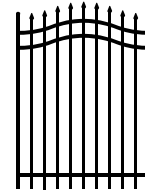

CLASSIC™

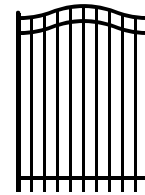

MAJESTIC™

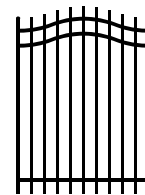

GENESIS™

☒ = FENCE STYLES AVAILABLE | **C** = Classic **M** = Majestic **G** = Genesis

ⓧ = COLOR OPTIONS AVAILABLE | **B** = Black

⊙ = NON-STOCKED PRODUCT | For details, see Ameristar's Sales Policy in the catalog guide.

Notes: Gate heights are nominal & gate widths are actual. Gate hardware sold separately. See Ornamental Gate Hardware section for more details.

Effective: 05/01/24

MONTAGE® | 3-RAIL SINGLE ARCHED SWING GATES

4" AIR GAP | FLUSH BOTTOM | GATE HARDWARE SOLD SEPARATELY

	OPENING	LEAF WIDTH	ITEM NUMBER	PICKET QTY	WEIGHT	STOCKING
3' HEIGHT	3.5'	36.5"	W☒ⓧ334F-42A	7	21 lbs	☉
	4'	45"	W☒ⓧ334F-48A	9	24 lbs	☉
	5'	62.5"	W☒ⓧ334F-60A	13	31 lbs	☉
	6'	71"	W☒ⓧ334F-72A	15	35 lbs	☉
3.5' HEIGHT	3.5'	36.5"	W☒ⓧ340F-42A	7	22 lbs	☉
	4'	45"	W☒ⓧ340F-48A	9	27 lbs	☉
	5'	62.5"	W☒ⓧ340F-60A	13	34 lbs	☉
	6'	71"	W☒ⓧ340F-72A	15	39 lbs	☉
4' HEIGHT	3.5'	36.5"	W☒ⓧ346F-42A	7	26 lbs	☉
	4'	45"	W☒ⓧ346F-48A	9	30 lbs	☉
	5'	62.5"	W☒ⓧ346F-60A	13	38 lbs	☉
	6'	71"	W☒ⓧ346F-72A	15	43 lbs	☉
4.5' HEIGHT	3.5'	36.5"	WMⓧ354F-42A	7	29 lbs	☉
	4'	45"	WMⓧ354F-48A	9	33 lbs	☉
	5'	62.5"	WMⓧ354F-60A	13	41 lbs	☉
	6'	71"	WMⓧ354F-72A	15	46 lbs	☉
5' HEIGHT	3.5'	36.5"	W☒ⓧ358F-42A	7	31 lbs	☉
	4'	45"	W☒ⓧ358F-48A	9	36 lbs	☉
	5'	62.5"	W☒ⓧ358F-60A	13	44 lbs	☉
	6'	71"	W☒ⓧ358F-72A	15	50 lbs	☉
6' HEIGHT	3.5'	36.5"	W☒ⓧ370F-42A	7	36 lbs	☉
	4'	45"	W☒ⓧ370F-48A	9	40 lbs	☉
	5'	62.5"	W☒ⓧ370F-60A	13	50 lbs	☉
	6'	71"	W☒ⓧ370F-72A	15	57 lbs	☉

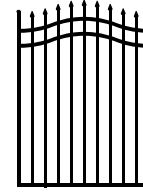

CLASSIC™

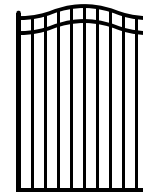

MAJESTIC™

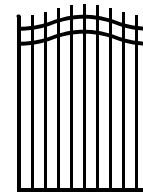

GENESIS™

☒ = FENCE STYLES AVAILABLE | C = Classic | M = Majestic | G = Genesis

ⓧ = COLOR OPTIONS AVAILABLE | B = Black

☉ = NON-STOCKED PRODUCT | For details, see Ameristar's Sales Policy in the catalog guide.

Notes: Gate heights are nominal & gate widths are actual. Gate hardware sold separately. See Ornamental Gate Hardware section for more details.

Effective: 05/01/2024

TO PLACE YOUR ORDER CALL 888-333-3422 | VISIT AMERISTARPERIMETER.COM |

AMERISTAR
ASSA ABLOY

MONTAGE® | GATE KITS & GATE ENDS

SINGLE SWING GATE KIT

PANEL HEIGHT	GATE END LENGTH	ITEM NUMBER	WEIGHT
4'	46"	W⊗46-WG	14 lbs
5'	58"	W⊗58-WG	16 lbs
6'	70"	W⊗70-WG	18 lbs

Each single swing gate kit includes:
 (2) Gate Ends / 1.25" sq. | (2) Frame Hinges / Female / 1.25" sq.
 (2) Post Hinges / Male / 2" sq. | (1) Latch Fork / 2" | (1) Latch Collar / 1.25"

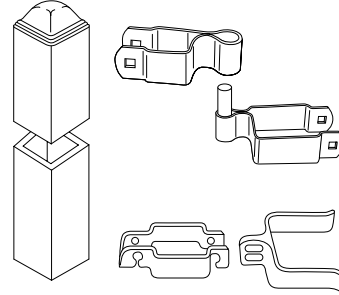

DOUBLE SWING GATE KIT

PANEL HEIGHT	GATE END LENGTH	ITEM NUMBER	WEIGHT
4'	46"	W⊗46-DD	32 lbs
5'	58"	W⊗58-DD	36 lbs
6'	70"	W⊗70-DD	40 lbs

Each double swing gate kit includes:
 (4) Gate Ends / 1.25" sq. | (6) Frame Hinges / Female / 1.25" sq. | (1) Cane Bolt / 48"
 (4) Post Hinges / Male / 2" sq. | (1) Latch Fork / 1.25" | (1) Latch Collar / 1.25"

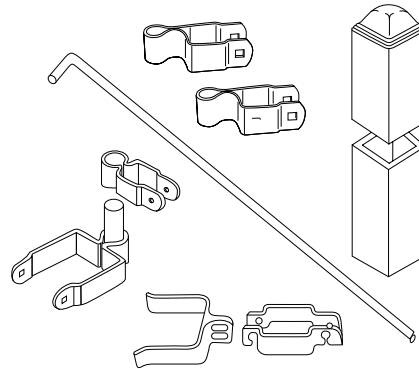

⊗ = COLOR OPTIONS AVAILABLE | B = Black

Notes: Gate kits intended for use with Majestic flush bottom panels should be purchased one foot taller than panel height. Gates fabricated by welding gate ends to panel remnants are excluded from Ameristar's welded fence warranty.

GATE ENDS

LENGTH	ITEM NUMBER	BOX QTY	WEIGHT
1.25" x 34"	H⊗234	8	2.90 lbs
1.25" x 40"	H⊗240	8	3.45 lbs
1.25" x 46"	H⊗246	8	3.83 lbs
1.25" x 48"	H⊗248	8	4.00 lbs
1.25" x 58"	H⊗258	8	4.95 lbs
1.25" x 59"	H⊗259	8	5.05 lbs
1.25" x 70"	H⊗270	8	6.00 lbs
1.25" x 71"	H⊗271	8	6.30 lbs

⊗ = COLOR OPTIONS AVAILABLE | B = Black

Notes: 1.25" sq. PVC caps are included in box for each gate end.

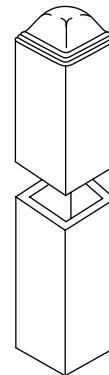

Effective: 05/01/24