

PERMACOAT[®] & GALVONALL[™]



FENCE PRODUCTS

AMERISTARPERIMETER.COM | 888-333-3422

Experience a safer and more open world

AMERISTAR[®]

ASSA ABLOY

PERMACOAT

Color Chain-link Framework

Ameristar's PermaCoat color chain-link fencing was developed to answer the need for a more durable, yet attractive and affordable option for fencing projects that can artfully blend into the natural environment to enhance any installation.

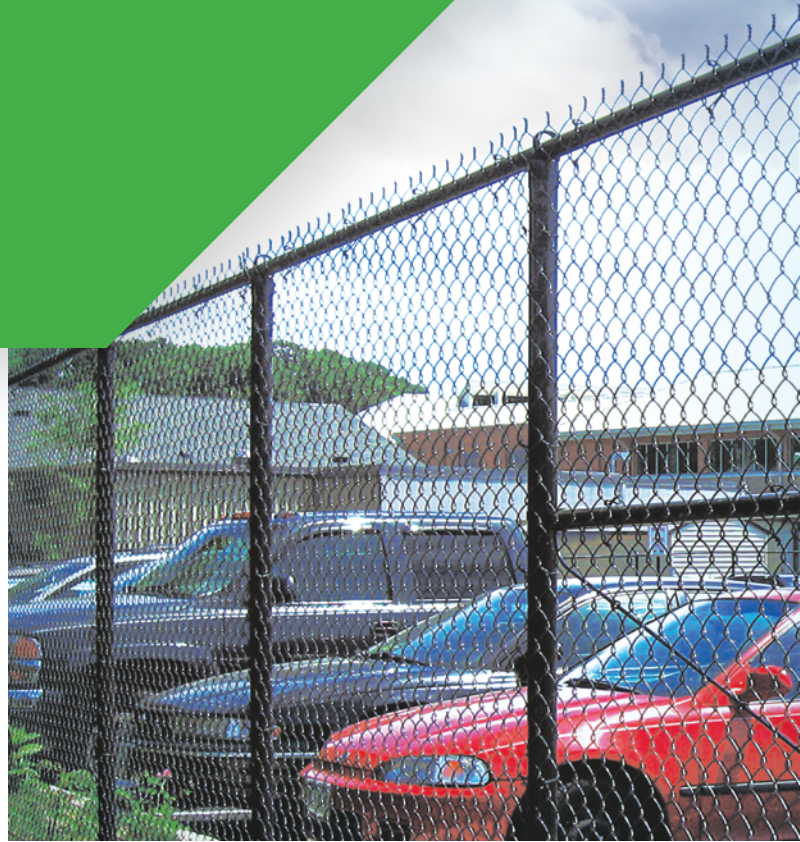

*"No-Mar" Polyester
Color Coat*

Epoxy Powder Coat

*Galvanized Steel
(Outside)*

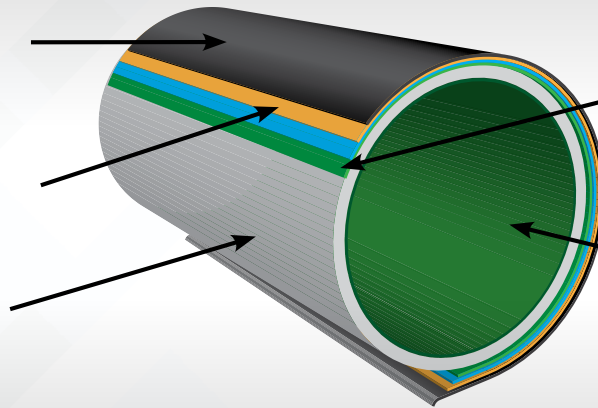

*Zinc
Phosphate*

*Zinc-Rich I.D.
Coating (Inside)*



PERMACOAT FABRIC

Color options include green, brown or black. PermaCoat comes with an offer of a 15-year warranty against cracking, chipping, peeling, blistering and corroding.

GREEN

BROWN

BLACK

PERMACOAT COATING PROCESS

PRE-TREATMENT

Once completed, these 7 stages will have removed everything from the surface of the steel that might inhibit the finish from properly adhering during the next 4 stages of the coating process.

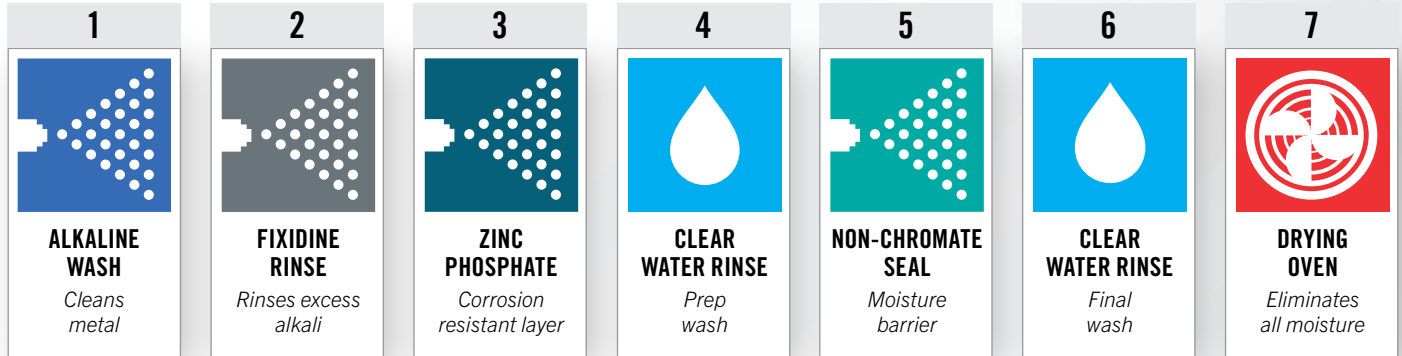

DOUBLE COATING

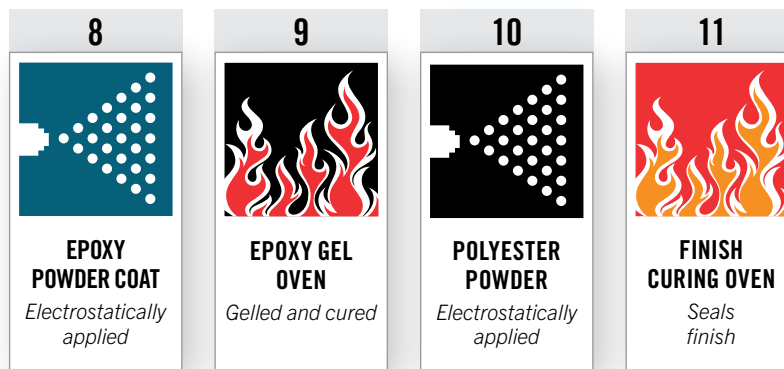

CORROSION TESTING

Corrosion occurs more easily without the proper preparation and protection, which is why Ameristar has put our fence products to the test based on ASTM B117 standards. The results speak for themselves.

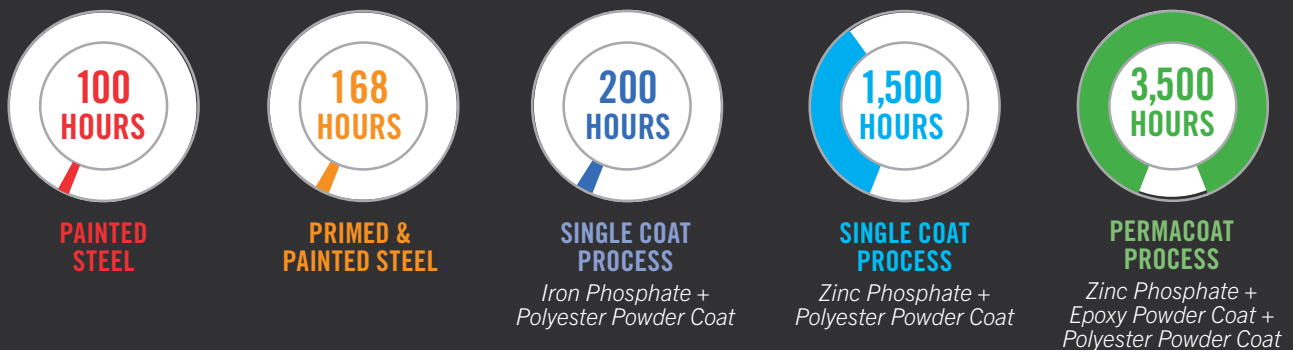

GALVONALL

Galvanized Chain-link Framework

Whether your need is for residential, commercial or industrial chain-link fence, GalvOnAll is the ideal framework for your fencing project because it's produced from high-yield strength, pre-galvanized steel using state-of-the-art mill-forming and in-line welding.

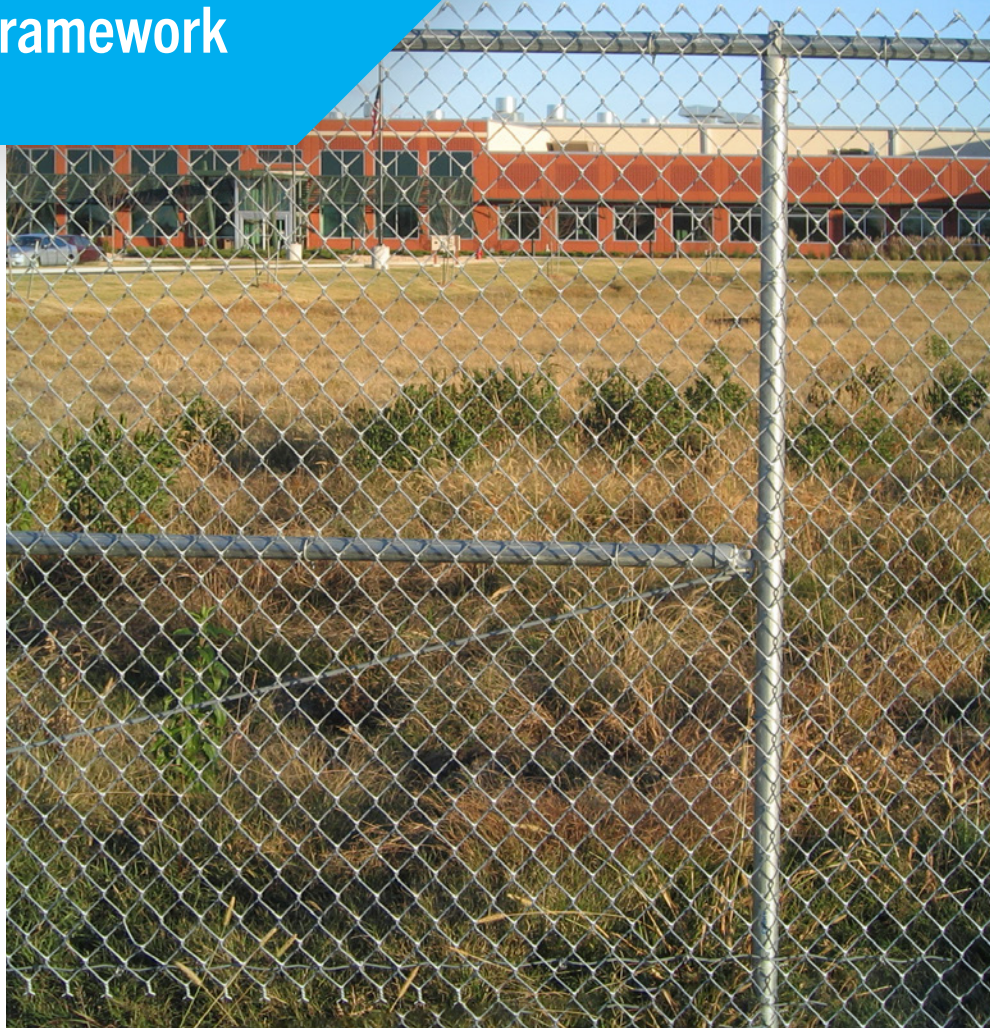

*Continuous 1.0 oz/ft²
+/- 0.1 oz/ft² hot-dip
galvanized coating*

*Cold-rolled, high-strength steel
provides a minimum-yield
strength of 50,000 psi*

90% zinc-rich interior coating

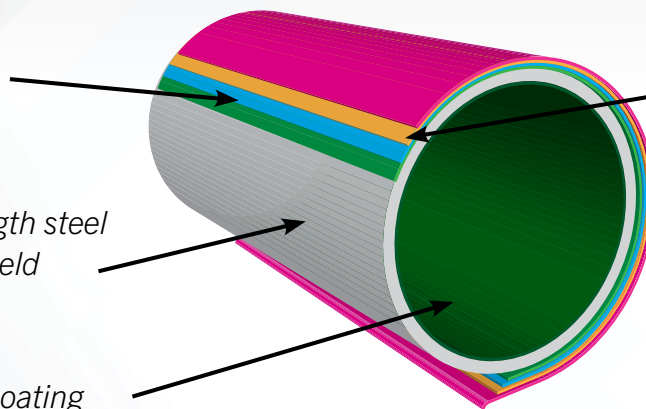

*Intermediate
conversion coating
inhibits white rust*

*Clear polymer coating
seals in protection, and
provides a smooth,
lustrous finish*

Note: All GBR40 products are stenciled as AMERISTAR 40 WT MADE IN USA



EXCEPTIONAL STRENGTH

The high-tensile steel and advanced roll-forming process used to produce GalvOnAll GBR-40 chain-link fence framework results in superior strength and consistent galvanized protection on both the outside and inside surfaces. GalvOnAll's total protection process achieves much greater corrosion and exposure resistance than conventional galvanized framework employing a painted interior.



MEETING THE STANDARDS

Permacoat and GalvOnAll meet multiple industry standards, making them the minimum requirement for many state and city codes including:

- ASTM F1043 Specification for Strength and Protective Coatings on Metal Industrial Chain-link Fence Framework
- RR-F-191/3 Federal Specification Sheet for Fencing, Wire and Post, Metal (Chain-Link Fence Posts, Top Rails and Braces)
- AASHTO M1B1 Standard Specification for Chain-Link Fence

SUPERIOR SYSTEM



PHYSICAL DIMENSIONS & STRENGTH CHARACTERISTICS

**1 5/8" TOP RAIL
10' FREE SUPPORT BEAM**

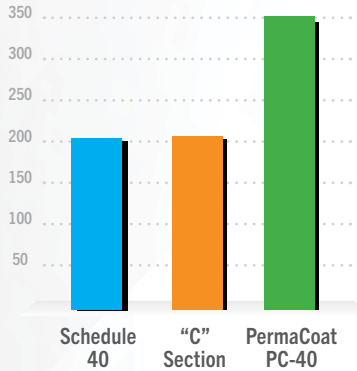

**2" LINE POST
6' CANTILEVER TEST**

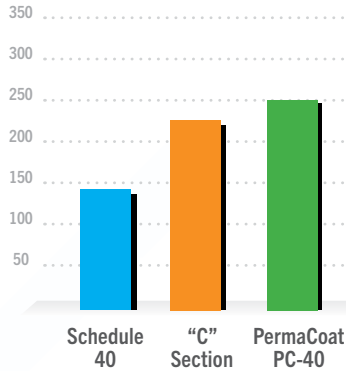

**2 1/2" LINE POST
6' CANTILEVER TEST**

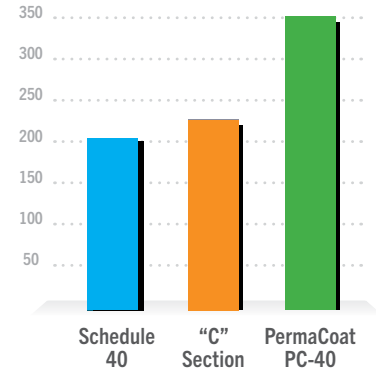

FENCE INDUSTRY O.D.	NOMINAL PIPE SIZE I.D.	ACTUAL O.D. (IN.)	WALL THICKNESS (IN.)	WT./FT. (POUNDS)	MIN. YIELD STRENGTH	X	(1) SECTION MODULUS	=	MAX. BENDING MOMENT LBS./IN.	10' FREE SUPPORTED LBS.	CALCULATED LOAD (LBS.)	
											4'	6'
1 5/8	1 1/4	1.660	.111	1.84	50,000	X	.1961	=	9,805	327	204	136
2	1 1/2	1.900	.120	2.28	50,000	X	.2810	=	14,050	468	293	195
2 1/2	2	2.375	.130	3.12	50,000	X	.4881	=	24,405	814	508	339
3	2 1/2	2.875	.160	4.64	50,000	X	.8778	=	43,890	1,463	914	610
4	3 1/2	4.000	.160	6.56	50,000	X	1.7819	=	89,095	2,970	1,856	1,237

(1) Nominal O.D. and minimum wall thickness



The powder coated surface on all Ameristar PermaCoat and GavOnAll framework is guaranteed under normal and proper usage for 15 years.

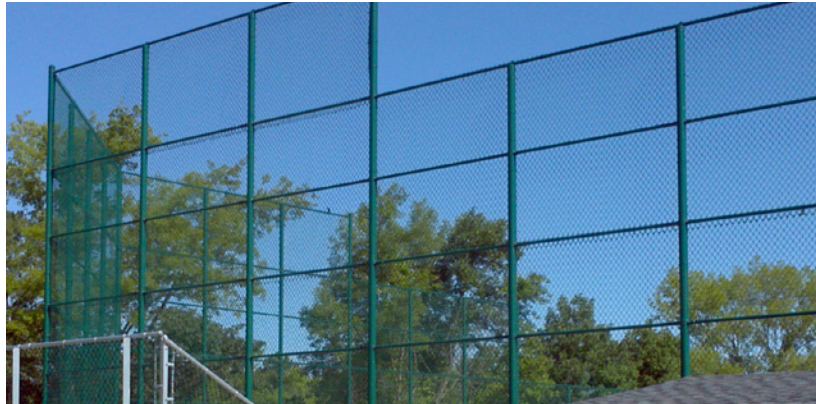

PRODUCT OFFERING

ROUNDS

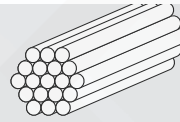

PRODUCT	FENCE OD	DECIMAL EQUIVALENT	19 GA	18 GA	17 GA	16 GA	14 GA	12 GA	11 GA	PC -20	PC -40	GBR -20	GBR -40
PERMACOAT	1 3/8	1.375			●	●							
	1 5/8	1.625				●				●	●		
	1 7/8	1.875				●				●	●		
	2 3/8	2.375				●				●	●		
	2 7/8	2.875								●	●		
	4	4.000									●		
GALVONALL	1 3/8	1.315		●	●	●							
	1 5/8	1.660		●	●	●						●	●
	1 7/8	1.900		●	●	●						●	●
	2 3/8	2.375		●	●	●						●	●
	2 7/8	2.875										●	●
	4	4.000											●

SQUARES

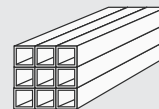

PRODUCT	FENCE OD	DECIMAL EQUIVALENT	19 GA	18 GA	17 GA	16 GA	14 GA	12 GA	11 GA
GALVONALL	5/8	.590	●	●	●	●			
	5/8	.625	●	●	●	●			
	3/4	.750		●	●	●			
	1	.975		●		●	●		
	1	1.0		●		●	●		
	1 1/4	1.25				●			
	1 1/2	1.5				●	●		
	1 3/4	1.75					●		
	2	2.0				●	●	●	
	2 1/2	2.5				●	●	●	

Why Choose Ameristar?

KNOWLEDGE AND EXPERIENCE

For over 40 years we've delivered aesthetically pleasing, high-quality and innovative fencing products with superior design strength and easy installation.

PROVEN CAPABILITIES

Our integrated in-house processes, extensive raw materials and finished goods inventory translate into quality, on-time delivery.

INDUSTRY LEADERSHIP

We continually raise the bar in manufacturing customer-focused solutions. Our high standards produce premium products that go beyond merely meeting minimum industry standards.



Scan to learn
more about
PermaCoat®



Scan to learn
more about
GalvOnAll™



AMERISTARPERIMETER.COM | 888-333-3422
Experience a safer and more open world

#6018 | 04/2024

AMERISTAR®

ASSA ABLOY