

STANDARD FEATURES:

- CERTIFIED ASTM F2656-20 M30/P1 (DP* 3.05 LF)
 - TESTED AS A SINGLE BOLLARD CONFIGURATION
- CLEAR OPENING 48"
- HYDRAULIC POWER UNIT (HPU) AND OPERATOR CONTROLS
- LOST CASING DESIGN
- HOT DIPPED GALVANIZED STEEL
- *DYNAMIC PENETRATION

OPTIONAL:

- CUSTOM COLORS
- COLD WEATHER KITS
- POST-MOUNTED TRAFFIC SIGNAL
- BATTERY BACKUP
- VEHICLE LOOP DETECTION
- PRIMARY AND REMOTE CONTROLS
- EMERGENCY FAST OPERATION (EFO)

NOTES:

- INSTALLATION BY OTHERS
- REFER TO PROJECT-SPECIFIC SUBMITTALS FOR SPECIFICATIONS AND DETAILS
- REACH OUT TO YOUR AMERISTAR BARRIER REPRESENTATIVE FOR A FULL LIST OF OPTIONS AND PROJECT COORDINATION AT PH 866-467-2773 OR AMERISTARBARRIERS@ASSAABLOY.COM

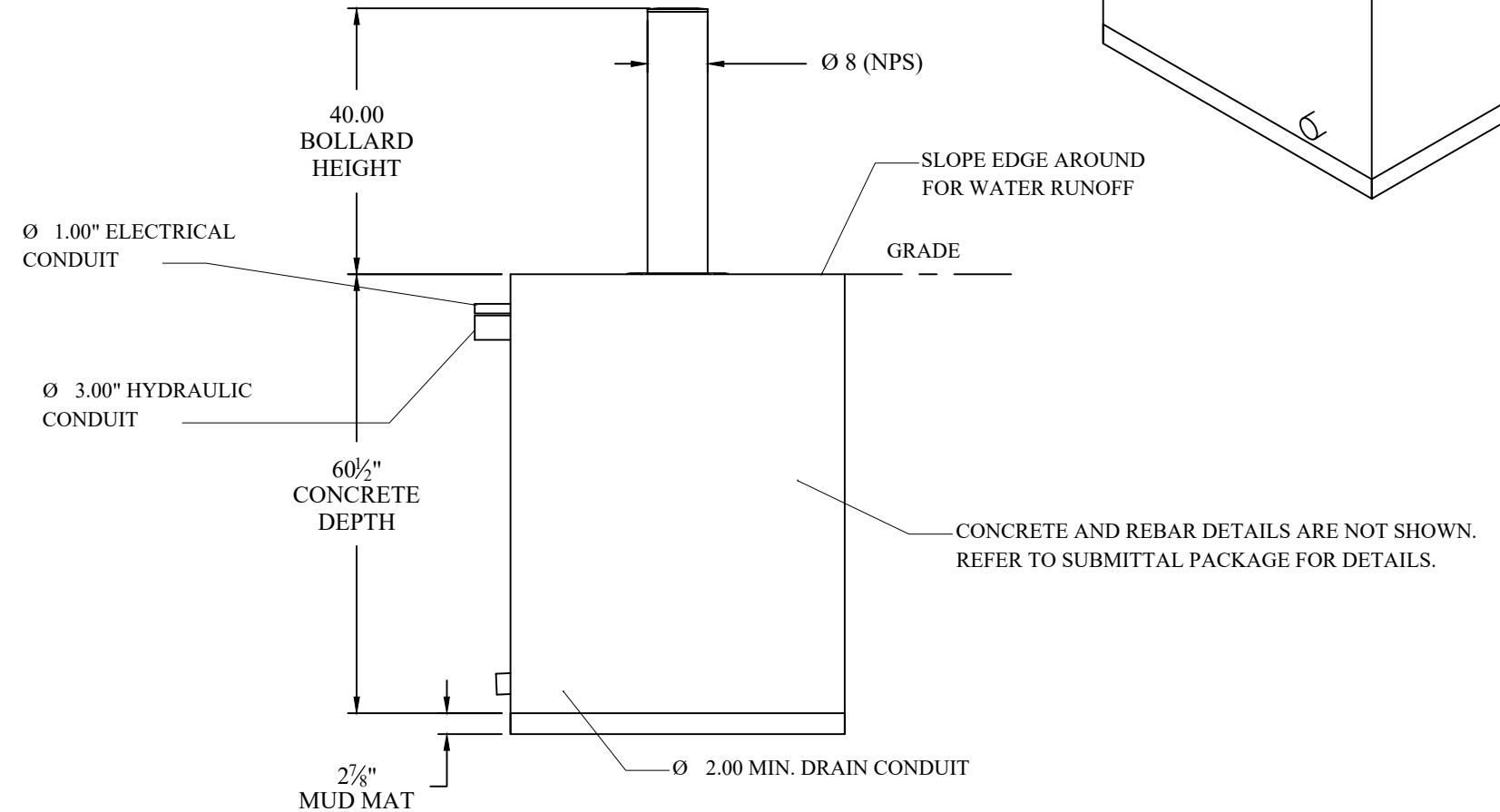
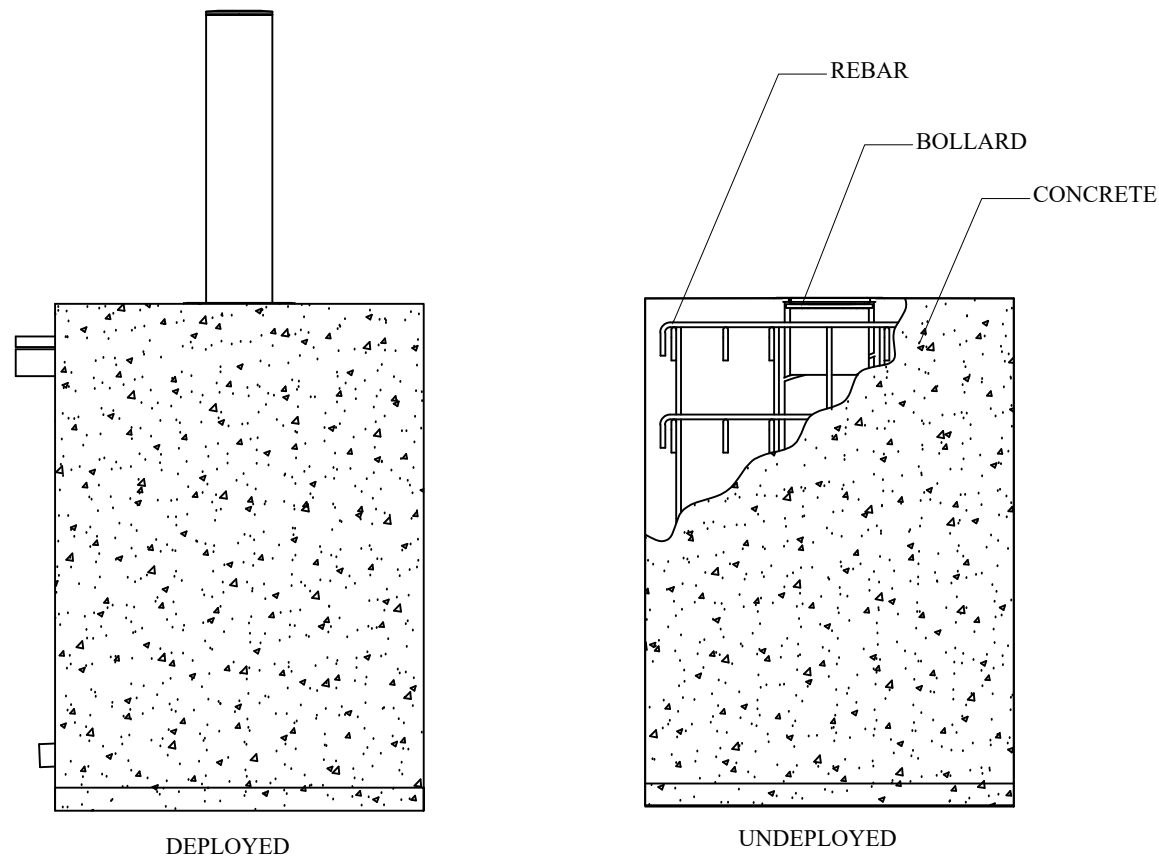
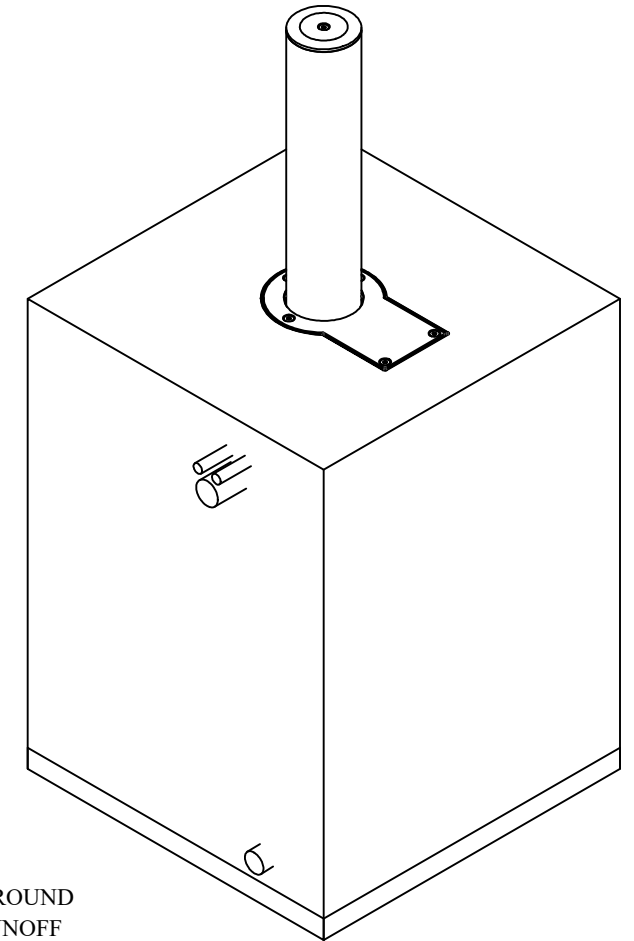
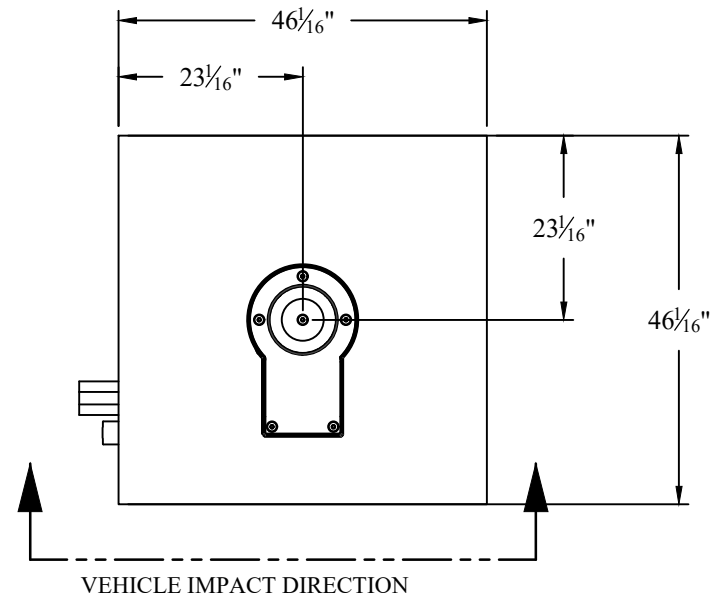

MODEL 303 M30 HYDRAULIC BOLLARD

REV A 9/2024



AMERISTARPERIMETER.COM | 866-467-2773

Experience a safer and more open world

